

DOCUMENT INCLUDES 3 PAGES

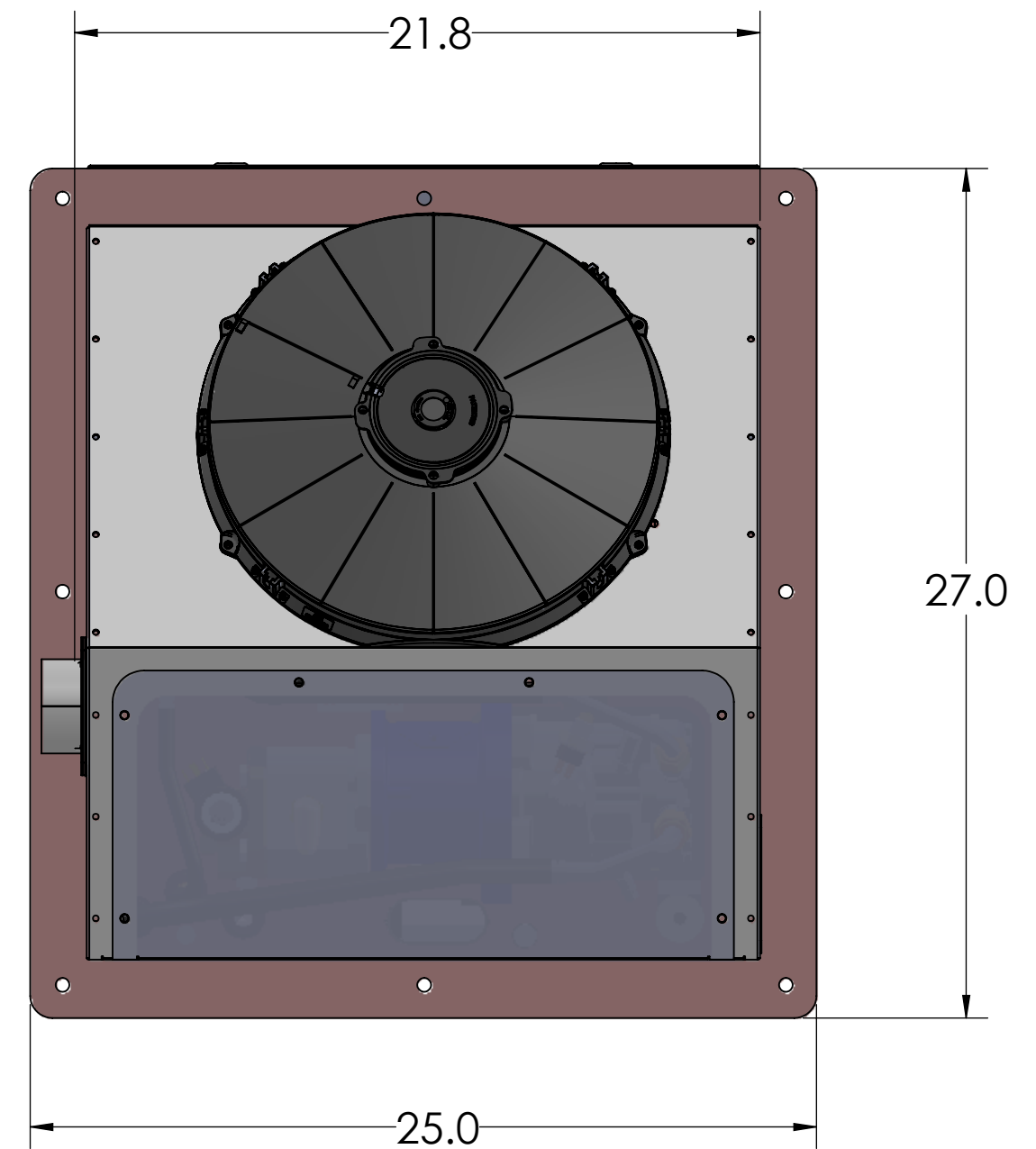
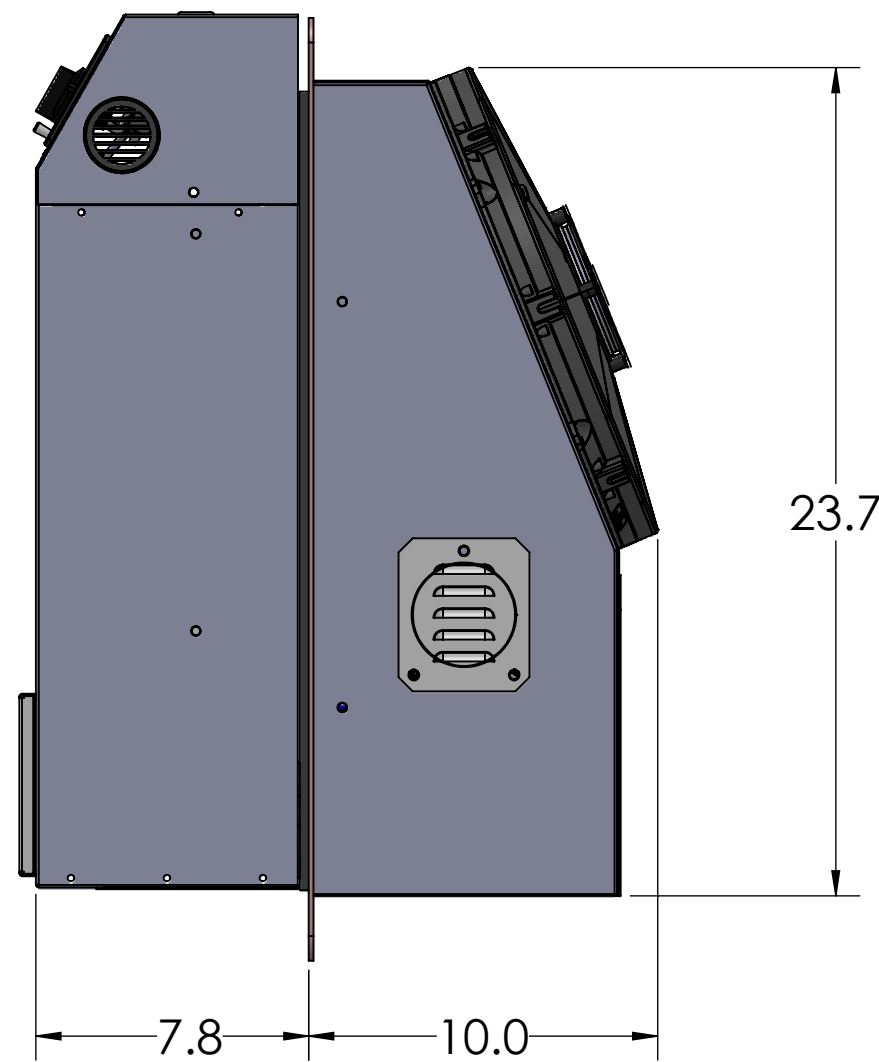
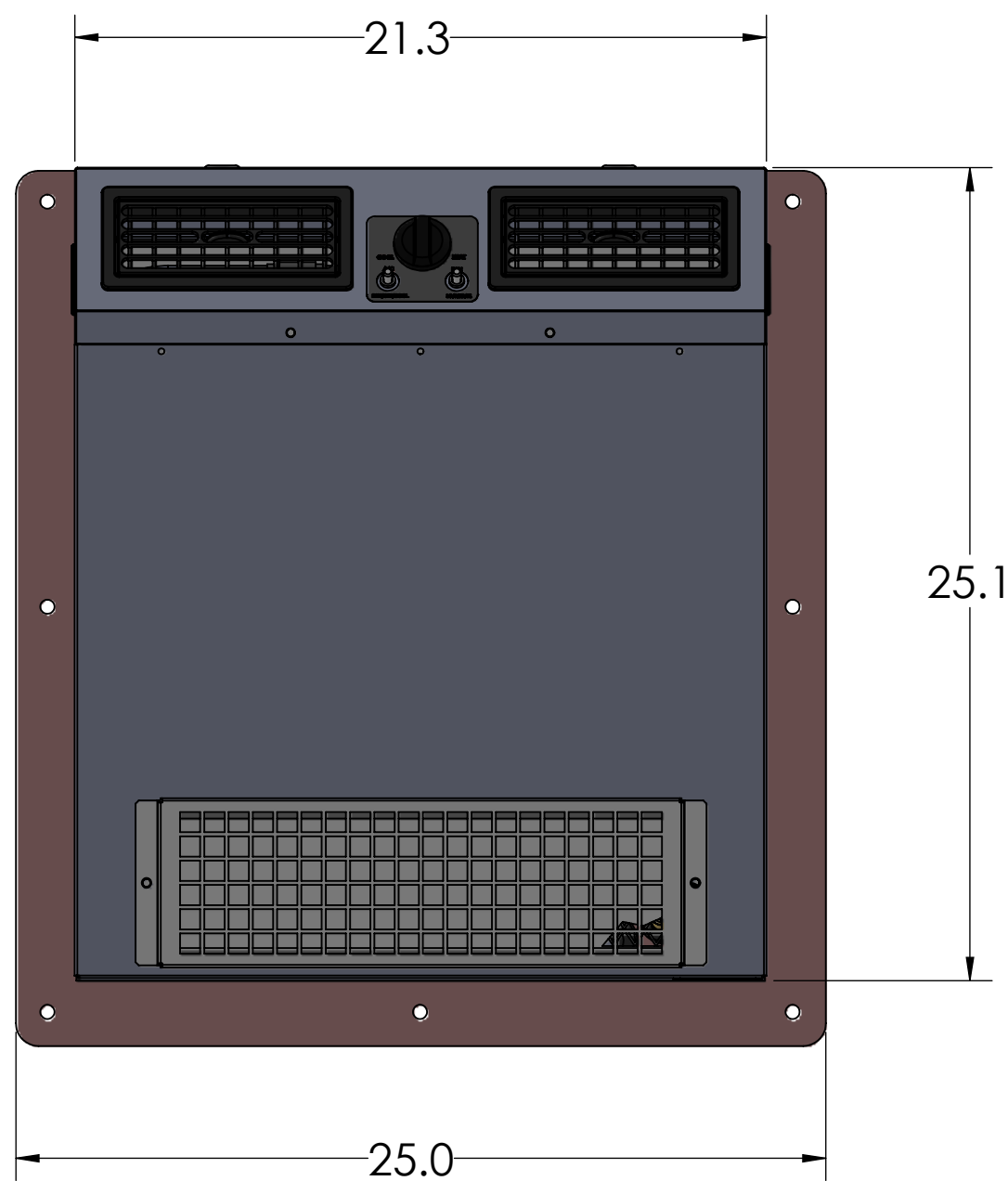
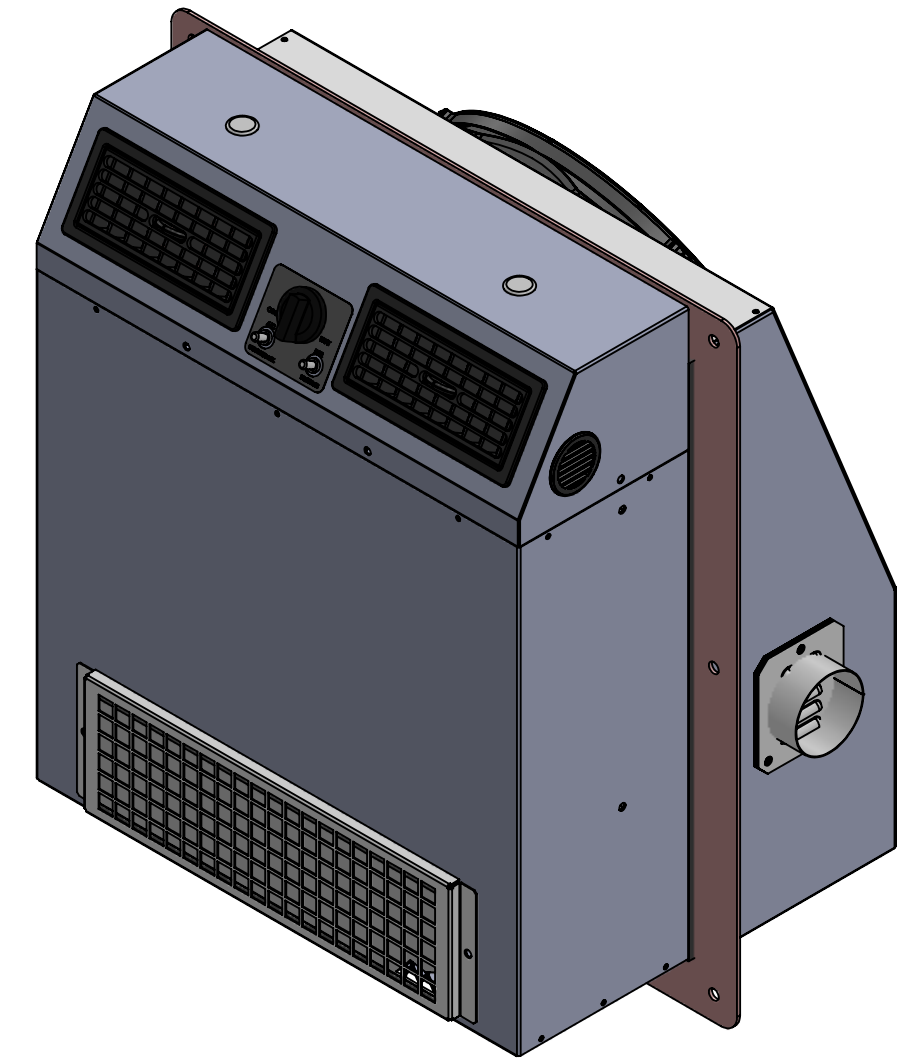
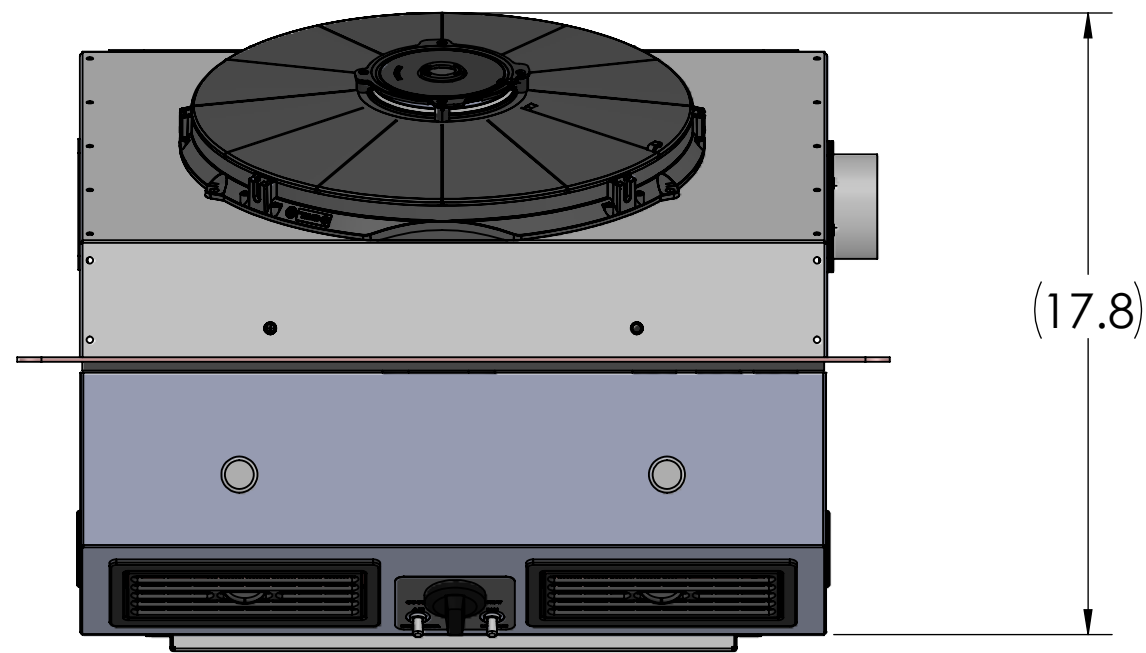

MODEL: 47-7150-1310 7150DD ACH 12V PRESSURE READY
 47-7150-1340 7150DD ACH 12V FRESH AIR
 47-7150-2310 7150DD ACH 24V PRESSURE READY
 47-7150-2340 7150DD ACH 24V FRESH AIR

VISIONAIRE, INC.
 MANUFACTURER AND DISTRIBUTOR OF HEATERS AND AIR CONDITIONERS FOR HEAVY EQUIPMENT
 1502 109th STREET
 GRAND PRAIRE, TEXAS 75050
 972-647-1056 www.visionaire-inc.com

DRAWN	NAME	DATE	DOCUMENT NO:
ENG APPR.	CNH	1/14/16	90-7150-001
	CHRIS	1/14/16	

SHEET 1 OF 3

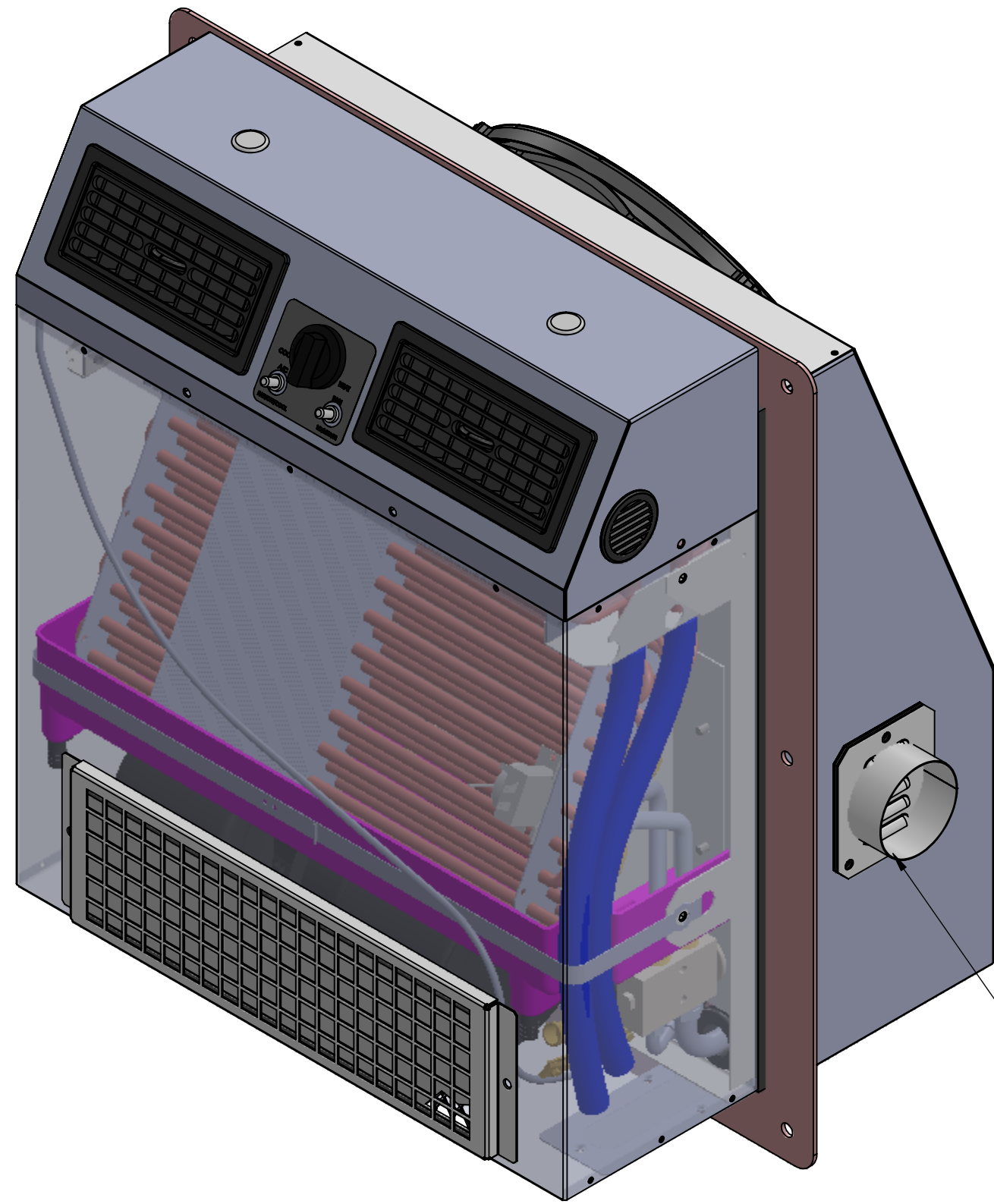

FRESH AIR OPTION

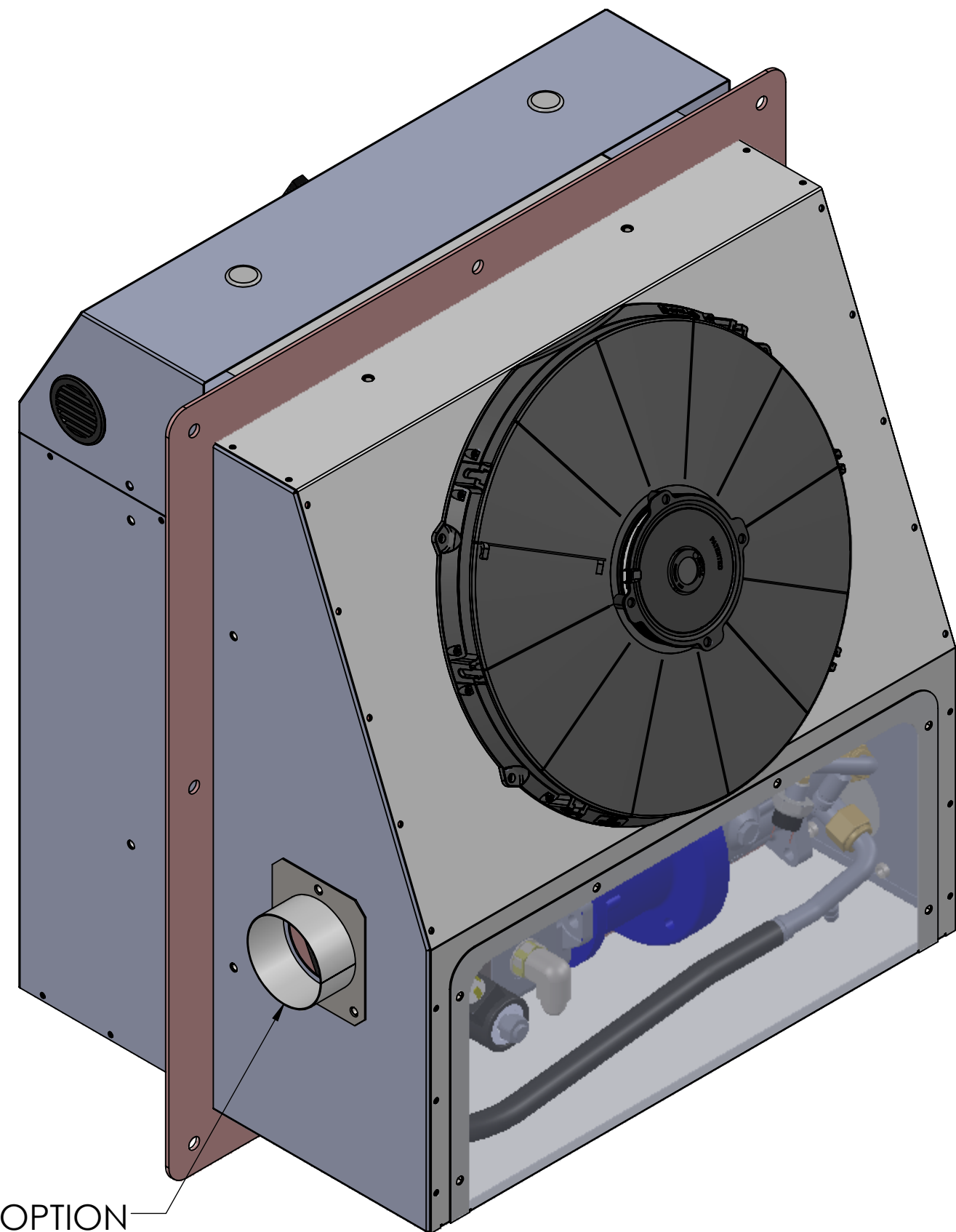

PRESSURIZER READY OPTION

VIEW SHOWING INSIDE EVAPORATOR

VIEW SHOWING INSIDE CONDENSER

SHOWN WITH CONTROL
BEZEL REMOVED

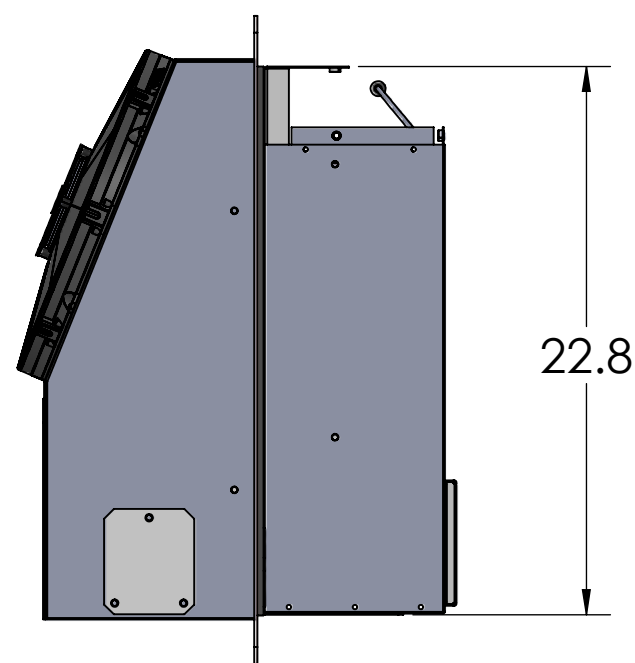

22.8

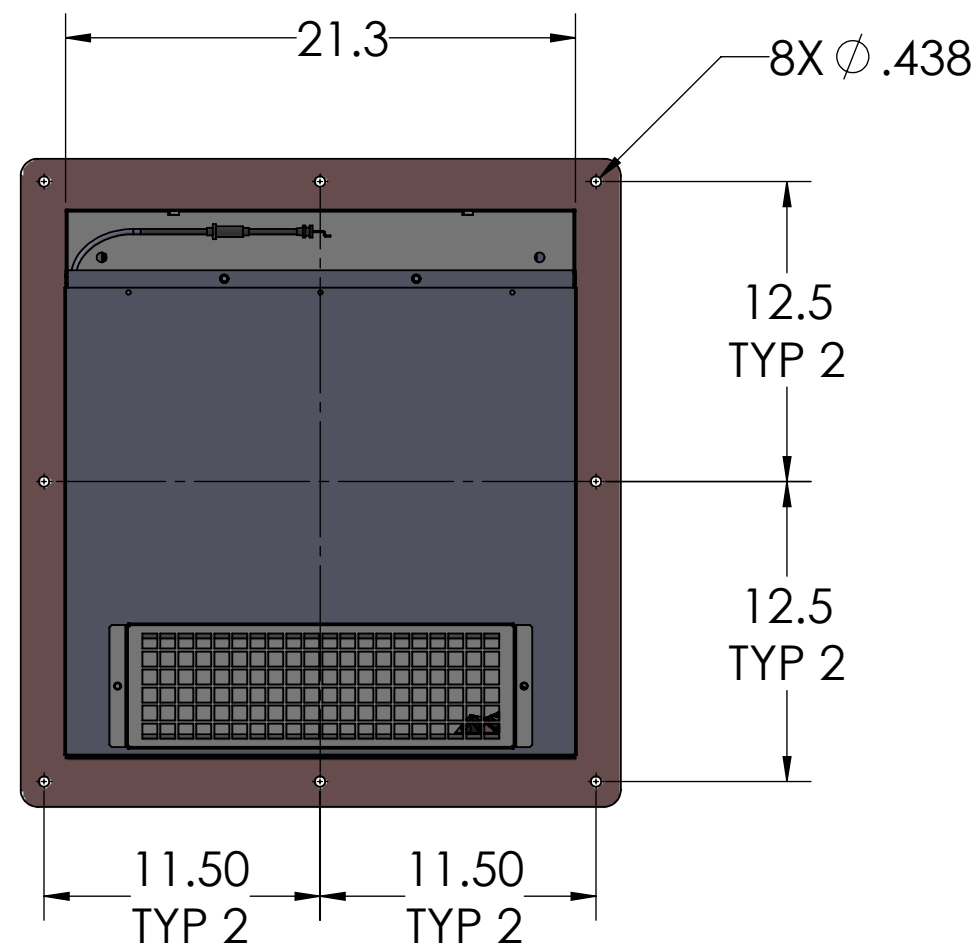

VIEW SHOWING WALL CUTOUT

VISIONAIRE, INC.
 MANUFACTURER AND DISTRIBUTOR OF HEATERS AND
 AIR CONDITIONERS FOR HEAVY EQUIPMENT
 1502 109th STREET
 GRAND PRAIRE, TEXAS 75050
 972-647-1056 www.visionaire-inc.com

	NAME	DATE	DOCUMENT NO:
DRAWN	CNH	1/14/16	90-7150-001
ENG APPR.	CHRIS	1/14/16	

SHEET 2 OF 3

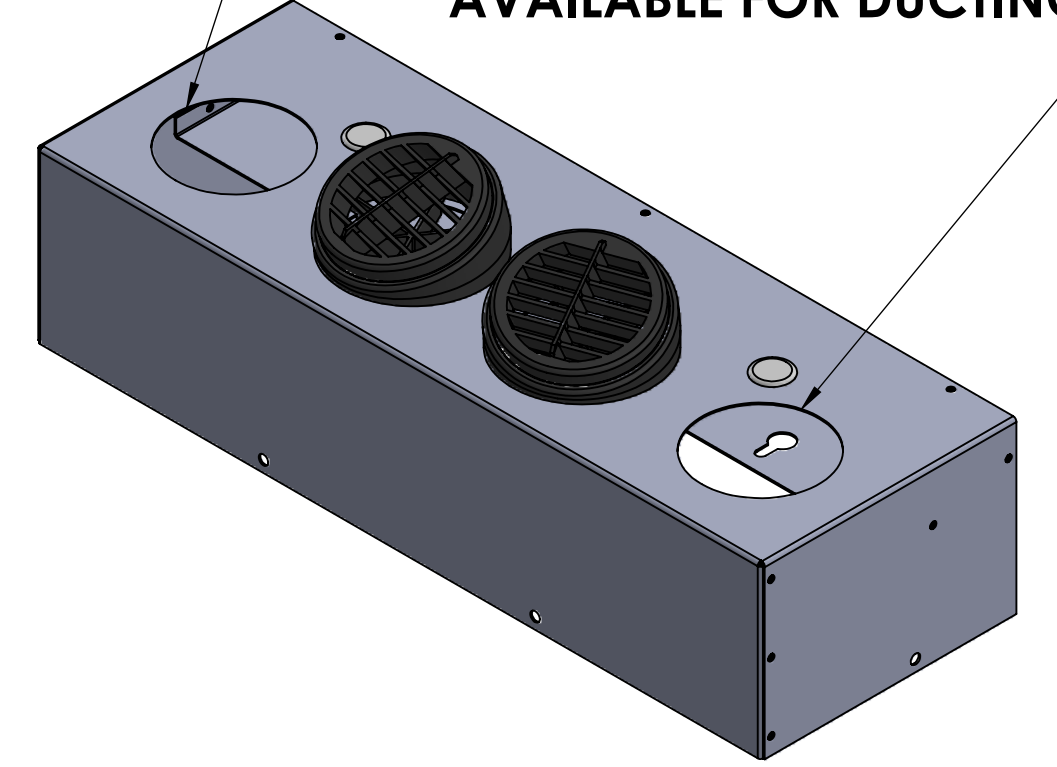
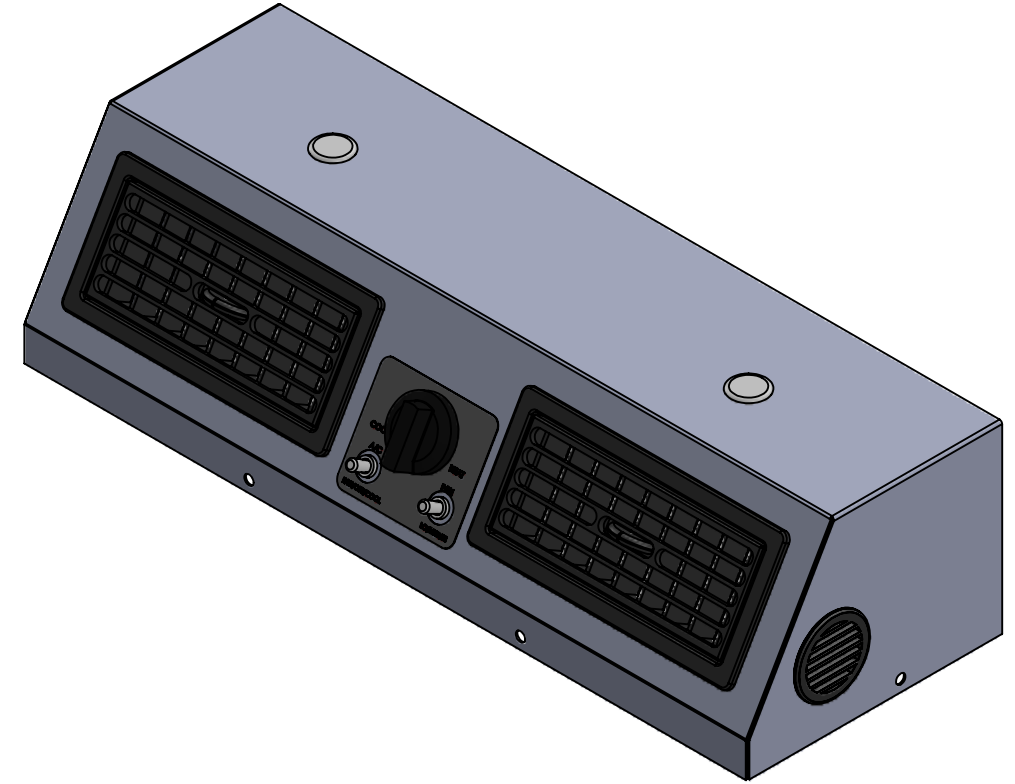
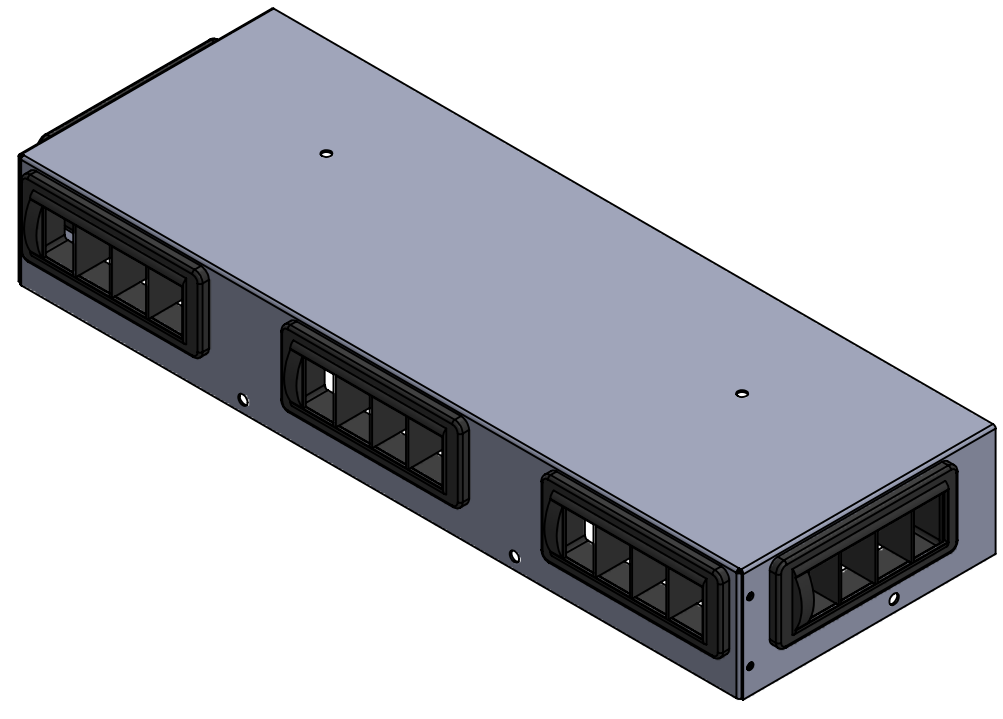
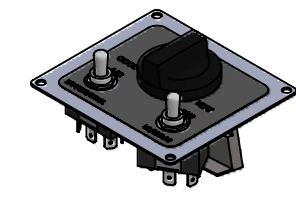
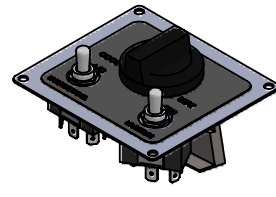

AVAILABLE FOR DUCTING

AVAILABLE FOR DUCTING

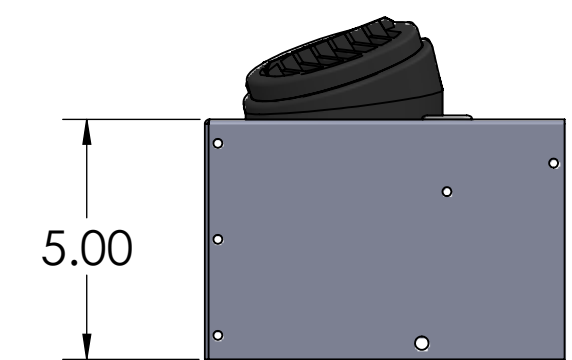
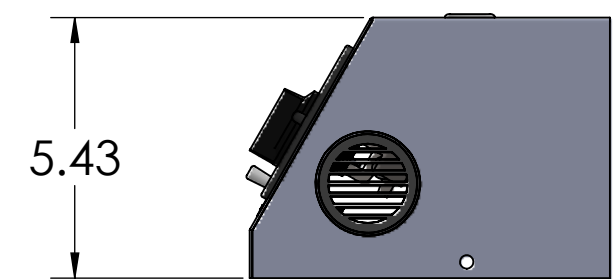
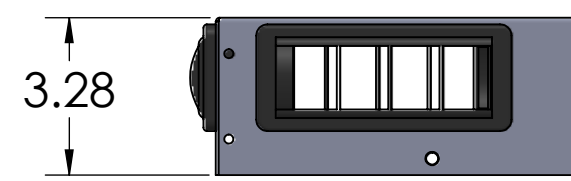

**OPTIONAL
FLAT TOP BEZEL WITH
REMOTE MOUNTED CONTROLS**

**BEZEL WITH INTEGRATED
CONTROLS
(STANDARD)**

**OPTIONAL
DUCTABLE BEZEL WITH
REMOTE MOUNTED CONTROLS**

SYSTEM SPECIFICATIONS:

- COOLING CAPACITY: 25,000 BTU/HR
- HEATING CAPACITY: 37,500 BTU/HR
- AIRFLOW: 420 CFM
- 3 SPEED BLOWER
- REFRIGERANT: R-134A
- ALL STEEL CONSTRUCTION
- REUSABLE WASHABLE FILTER
- 30A @ NOMINAL 12VDC
- 15A @ NOMINAL 24VDC

VISIONAIRE, INC.
 MANUFACTURER AND DISTRIBUTOR OF HEATERS AND
 AIR CONDITIONERS FOR HEAVY EQUIPMENT

1502 109th STREET
 GRAND PRAIRE, TEXAS 75050

972-647-1056 www.visionaire-inc.com

	NAME	DATE	DOCUMENT NO:
DRAWN	CNH	1/14/16	90-7150-001
ENG APPR.	CHRIS	1/14/16	

SHEET 3 OF 3