

UNLESS OTHERWISE SPECIFIED:

DIMENSIONS ARE IN INCHES
 TOLERANCES:
 FRACTIONAL $\pm 1/16"$
 ANGULAR: BEND ± 1 DEG
 TWO PLACE DECIMAL ± 0.030
 THREE PLACE DECIMAL ± 0.010

INTERPRET GEOMETRIC
 TOLERANCING PER:

MATERIAL

X

FINISH

--

	DATE	NAME
DRAWN	02/14/08	PDC
CHECKED		
ENG APPR.		
MFG APPR.		
Q.A.		
COMMENTS:		

VISIONAIRE, INC.

TITLE:
**HORIZONTAL
 PRESSURIZER**

SIZE B	DWG. NO.	REV 0
SCALE: 1:5	WEIGHT:	SHEET 1 OF 2

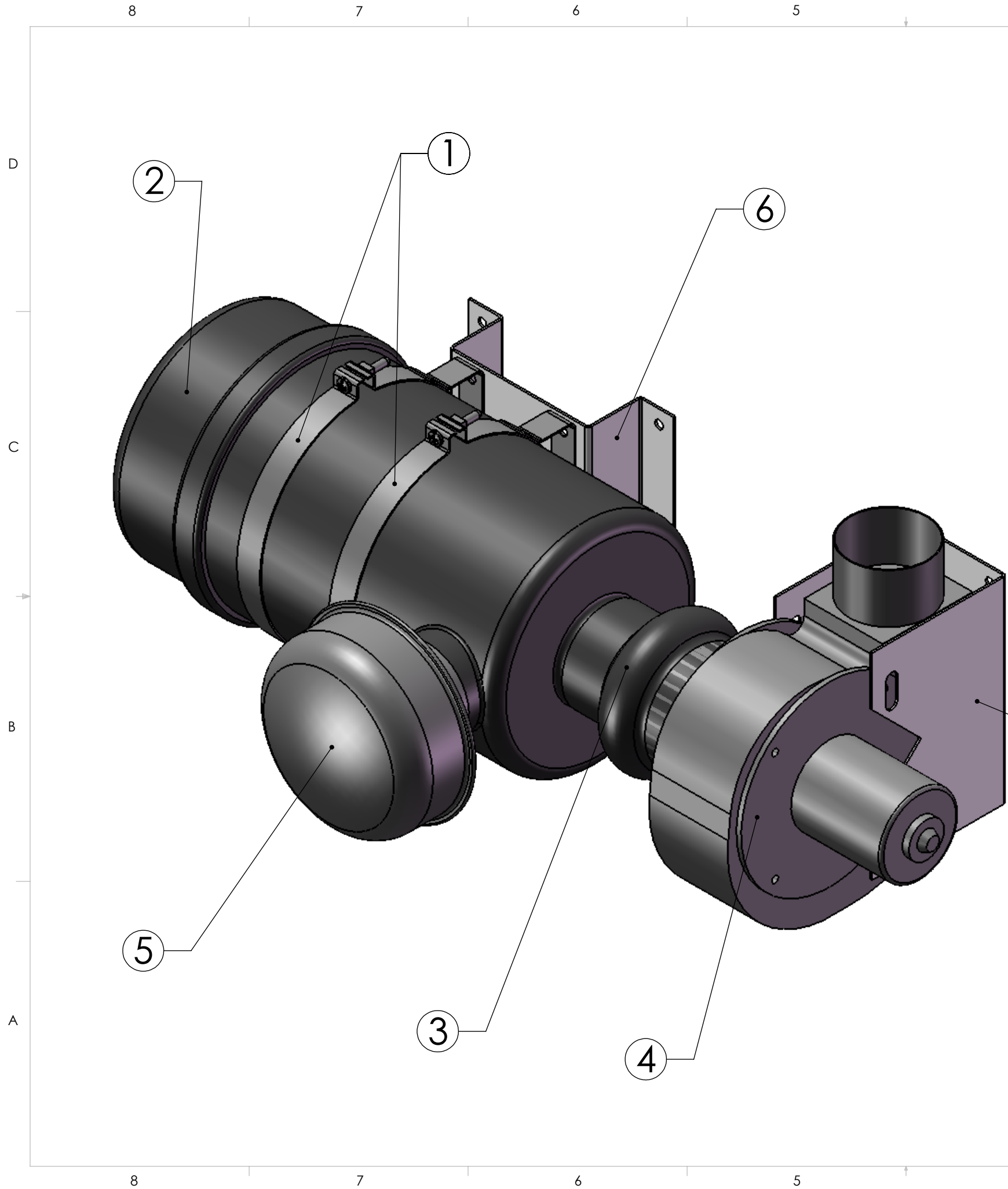

ITEM NO.	PART NUMBER	DESCRIPTION	QTY.
1	15-30-2901	P004307	2
2	15-30-2023	G080023	1
3	17-41-1430	P101290	1
4	14-20-1000	73R9202	1
5	15-30-2900	X002014	1
6	30-6000-001	FILTER BRACKET	1
7	30-6000-002	PRESSURE BLOWER BRKT	1

UNLESS OTHERWISE SPECIFIED:		DATE	NAME	VISIONAIRE, INC. TITLE: HORIZONTAL PRESSURIZER	
DIMENSIONS ARE IN INCHES		DRAWN	02/14/08		SIZE B DWG. NO. REV 0
TOLERANCES:		CHECKED			
FRACTIONAL ± 1/16"		ENG APPR.			
ANGULAR: BEND ± 1 DEG		MFG APPR.		SCALE: 1:3	
TWO PLACE DECIMAL ± 0.030		Q.A.		WEIGHT:	
THREE PLACE DECIMAL ± 0.010		COMMENTS:		SHEET 2 OF 2	
INTERPRET GEOMETRIC TOLERANCING PER:					
MATERIAL X					
FINISH --					