

Air Heater

Air Top Evo 3900/5500 B (Gasoline) **Air Top Evo 3900/5500 D (Diesel)**

Installation Manual



WARNING!

- Improper installation or repair of Webasto heating and cooling systems can cause fire or the leakage of deadly carbon monoxide leading to serious injury or death.
- Installation and repair of Webasto heating and cooling systems requires special Webasto training, technical information, special tools and special equipment.
- NEVER attempt to install or repair a Webasto heating or cooling system unless you have successfully completed the factory training course and have the technical skills, technical information, tools and equipment required to properly complete the necessary procedures.
- ALWAYS carefully follow Webasto installation and repair instructions and heed all WARNINGS.
- Webasto rejects any liability for problems and damage caused by the system being installed by untrained personnel.
- Improper installation or installation by untrained personnel voids all warranties on this product.

Contents	Page
1. Safety and General Information	3
1.1 Warning Symbols in this Installation Manual	3
1.2 General Information	3
2. Regulations for Installation in the Vehicle	4
2.1 Scope	4
2.2 Position of the Heater	4
2.3 Fuel Supply	4
2.4 Exhaust System	4
2.5 Combustion Air Inlet	4
2.6 Hot Air Inlet	4
2.7 Hot Air Outlet	5
2.8 Automatic Control of the Heating System	5
3. Purpose of the Heater	6
4. Installation	7
4.1 Recommended Installation Tools	7
4.2 Air Top EVO 3900/5500 Installation Situation	7
4.3 Installation Location	8
4.4 To Install the Heater	8
4.5 Optional Mounting Plate	9
4.6 Factory Plate / Label	9
4.7 Installation Example	10
5. Hot Air System	11
5.1 External Temperature Sensor	12
5.1.1 To Install the External Temperature Sensor	12
6. Fuel Supply	13
6.1 Vehicles with a Carburetor Equipped Engine	13
6.2 Vehicles with Fuel Injection Engines	14
6.3 Vehicles with Diesel Engines	14
6.4 Fuel Lines	14
6.4.1 Connecting Two Fuel Lines with a Coupler Hose	15
6.5 Fuel Metering Pump	15
6.5.1 Installation Location	15
6.5.2 Installation and Attachment	16
6.6 Fuel Filter	16
7. Combustion Air Supply	17
8. Exhaust Pipe	18
9. Combustion Air Inlet and Exhaust Lines	19
10. Electrical Connections	20
10.1 Heater Connection	20
10.2 Supply Voltage Connection	20
10.3 Control Element (Rheostat) Connection	21
10.4 Installation Instructions for Control Panel MC04/05	22
10.4.1 MC04/05 Control Panel Connections	23
10.4.2 Combination Timer 1531 Connections	24
11. Circuit Diagrams	24
11.1 Legend for Circuit Diagrams	24

12.Starting the Heater for the First Time	28
12.1 Control Element Description	28
12.2 Ventilation Mode (Optional Connection)	28
13.Fault Lock-out	29
13.1 Error Code Output	29
14.Technical Data	30
14.1 Electrical Components.	30
14.2 Fuel for Air Top EVO 3900/5500 B (Gasoline).	30
14.3 Fuel for Air Top EVO 3900/5500 D (Diesel/Heating Oil)	30
15.Version	31
16.Drilling Template	32
17.Notes	33

1. Safety and General Information

1.1 Warning Symbols in this Installation Manual

The purpose of safety symbols is to attract your attention to possible hazardous conditions. This manual uses a series of symbols and signal words which are intended to convey the level of importance of the safety messages. The progression of symbols is described below. Remember that safety messages by themselves do not eliminate danger and are not a substitute for proper accident prevention measures.



Indicates an imminently hazardous situation which, if not avoided, WILL result in death or serious injury.



Indicates a potentially hazardous situation which, if not avoided, COULD result in death or serious injury.



Indicates a potentially hazardous situation which, if not avoided, MAY result in minor or moderate injury or property damage. It may also be used to alert against unsafe practices.

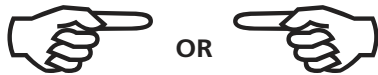

These symbols are used to alert the installer to important or useful information about proper installation of the equipment.

1.2 General Information

Webasto Product North America, Inc. is pleased to provide this installation manual with the AT 3900/5500 air heater. When installed according to the guidelines stated in this manual, you can expect your customer to enjoy many years of trouble-free heater operation.

This manual represents our latest effort to produce the best technical documentation possible. In our efforts towards continuous, ongoing product improvement, we encourage our customers to write to us with their comments or criticisms concerning this manual and the AT 3900/5500 air heating system.

Please write to us at:
Webasto Product North America, Inc.
Technical Documentation Group
15083 North Road
Fenton MI 48430

You are also invited to fill out our online questionnaire concerning our technical documentation and web site at:
www.techwebasto.com

If you have any immediate questions concerning this manual, the installation procedures within or the product itself, please call us at:

(800) 555-4518 or send a fax to: (810) 593-6001

2. Regulation for Installation in the Vehicle

Read this installation manual in its entirety before installing this equipment.

2.1 Legal Provisions

2.1.1 The installation and service of Webasto heaters requires special expertise and training. Installations and servicing of Webasto products by untrained, unauthorized personnel and end-users voids all warranties and releases Webasto Product North America, Inc. and Webasto authorized distributors, dealers and their personnel from responsibility for damage to Webasto products, any resulting collateral property damage and personal injury.

2.1.2 Any use, operation, installation, modification or application of the product not described in Webasto manuals, or subjecting the product to extreme or unusual conditions beyond the limits of specified performance characteristics is misuse of the product. Failure to comply with all installation instructions is a misuse of Webasto products. The same applies for repairs without using genuine Webasto service parts. This will void the heaters "official Marks of Conformity."



IMPORTANT!

All relevant state and provincial licensing regulations if any, governing the installation and use of auxiliary heating devices must be observed!

2.2 Position of the Heater

2.2.1 Parts of the vehicle body and other components in the immediate vicinity of the heater must be protected against excessive heat and the danger of contamination by fuel or oil.

2.2.2 The internal combustion heater must not pose a fire hazard even when overheated. This requirement is deemed to have been met if care is taken during installation to ensure an adequate distance from all parts, as well as adequate ventilation and if fire-resistant materials or heat shields are used.

2.2.3 For passenger carrying vehicles such as shuttle busses, transit busses, and coaches, the heater must not be installed in the passenger cabin. A device in a sealed cover, which also meets the requirements set out in paragraph 2.2.2, may be used, however.

2.2.4 The model/ Serial plate or a duplicate thereof (duplicate model/ Serial plate) must be fitted in such a way that it is still clearly legible when the heater has been installed in the vehicle.

2.2.5 When positioning the heater, all reasonable precautions must be taken to minimize the risk of personal injury or damage to items in the vehicle.

2.2.6 A clearly visible indicator within the user's field of vision must show when the heater is switched on or off.

2.3 Fuel Supply

2.3.1 Fuel lines are to be installed in such a way that they remain unaffected by torsional stresses created by vehicle and engine movement.

2.3.2 Fuel lines must be securely fastened to the vehicle every 12 inches (30 cm) or less along the total length from heater to fuel tank.

2.3.3 Fuel-carrying components must be protected against excessive heat and are to be installed so that any drippings or evaporating fuel can neither accumulate nor be ignited by hot components or electrical equipment.

2.3.4 In buses, fuel lines are not to be located in the passenger area or in the driver's compartment. Fuel supply must not be by means of gravity or pressurization of the fuel tank.

2.3.5 The fuel tank must be equipped with a vent cap or ventilated in another way (vent line).

2.3.6 When a separate fuel supply is used the fuel filler neck must not be located in the passenger compartment and must have a tightly fitting cap to prevent any fuel leaks.

2.3.7 The type of fuel and the fuel filler neck must be clearly identified for liquid fuel heaters which have a fuel supply separate from the vehicle fuel supply.

2.3.8 A label must be affixed to the fuel filler neck warning that the heater must be switched off before refuelling. An identical warning must also be included in the manufacturer's operating instructions.

2.4 Exhaust System

2.4.1 The exhaust outlet must be positioned in such a way that exhaust fumes cannot get into the interior of the vehicle through ventilation devices, hot-air inlets or open windows. Also note that exhaust should always point away from the direction of travel.

2.4.2 Do not route exhaust components within 100 mm (4 inches) of flammable materials such as fuel system components, polyurethane or similar foam insulation, styrene sheet installation, wood and paper products, carpet, glycol reservoirs, coolant lines, brake lines, electrical wiring, etc.

2.5 Combustion Air Inlet

2.5.1 The air for the combustion chamber of the heater must not be extracted from the passenger cabin of the vehicle.

2.5.2 The air inlet must be positioned in such a way that it cannot be obstructed by other objects.

2.6 Hot Air Inlet

2.6.1 The supply of heating air must consist of either fresh air or recirculated air and must be taken from a clean area which cannot be contaminated by exhaust fumes from the engine, the internal combustion heater or any other source in the vehicle.

2.6.2 The inlet line must be protected by a grating or other suitable means.

2.7 Hot Air Outlet

2.7.1 Hot air lines within the vehicle must be positioned or protected in such a way as to exclude all risk of injury or damage caused by direct contact.

2.7.2 The air outlet must be positioned or protected so that it cannot be obstructed by other objects.

2.8 Automatic Control of the Heating System

When the engine stops, the heating system must cut out automatically and the fuel supply must be stopped within 5 seconds.

The heating system may remain in operation if a manual unit has already been activated.

3. Purpose of the Air Heater

The Webasto Air Top EVO 3900/5500 air heaters are designed

- to heat cabins, boats **(Diesel Only)**, trucks, minibuses, vans and motor homes
- to defrost vehicle windows
- to heat cargo

The air heaters operate independently of the engine and are connected to the fuel tank and the electrical system of the vehicle.

They may be used for vehicles with either water or air-cooled engines.

They are not designed for heating hazardous substances.

4. Installation



IMPORTANT!

The regulations governing installation on pages 4 and 5 must be adhered to.

The heater must not be operated without the control unit cover (#9 below) (this will cause the heater to overheat).

4.1 Recommended Installation and Service Tools

- Digital Multi-Meter - Should be a good quality VAO meter.
- 1/2 Heavy-Duty, low speed drill with good quality, sharp drill bits and a selection of hole saws.
- Mounting/ Drilling Templates.

4.2 Air Top EVO 3900/5500 Installation Situation

NOTE:

Check the installation situation of the relevant vehicle type.

4.3 Installation Location

The heater may be fitted both in the interior or on the exterior of the vehicle.

If it is installed on the exterior ensure that the heater is fitted in a position where it is protected from splashing water and spray.

The heater must be installed in such a way that no water can ingress into it if the vehicle travels through a water hazard for which that vehicle is licensed.

The openings for the combustion air inlet port, the exhaust outlet port and the fuel line must be sealed if the heater is installed in the interior. The seal designed and supplied for this purpose must be used (see Figure 4). The same applies when using the optional mounting plate and closed cell foam gasket (see Figure 5).

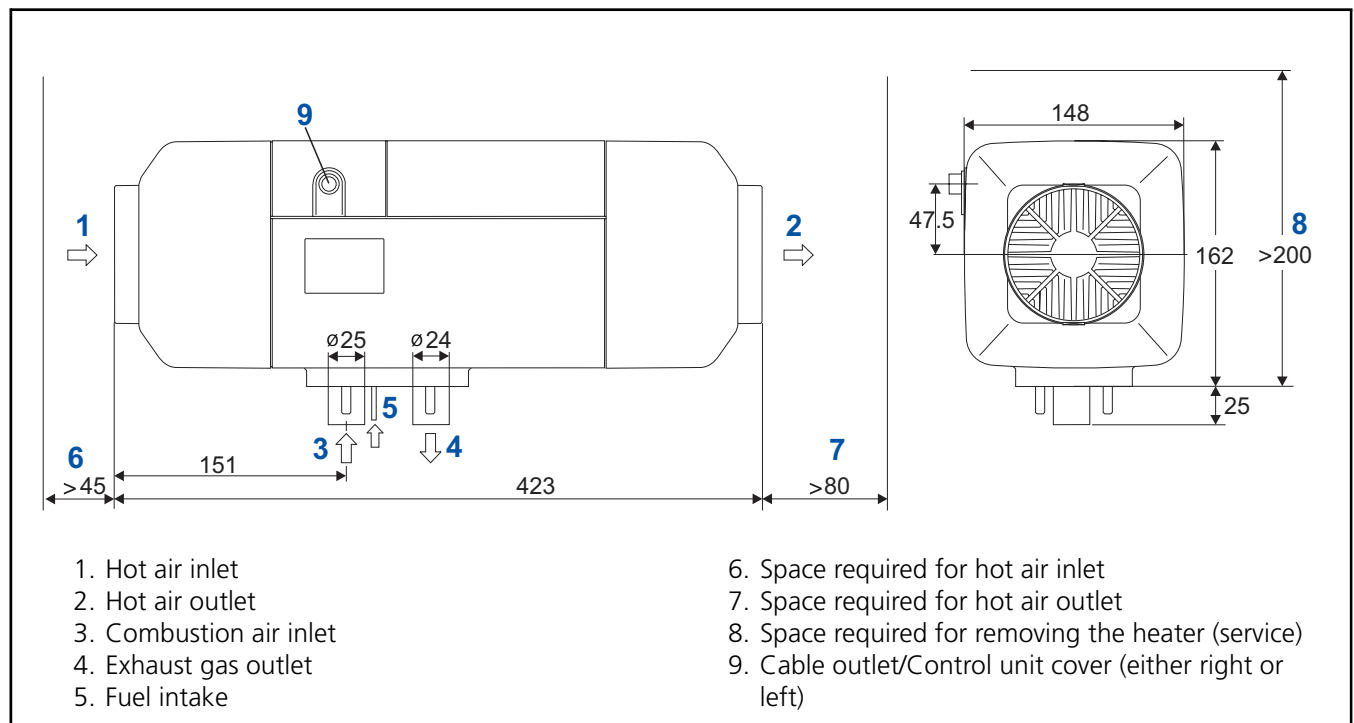

Figure 1. Dimensions of the Heater

4.4 To Install the Heater

The M6 nuts used to install the heater must be tightened with a torque of 6 Nm \pm 1 Nm (4.4 lb.-ft \pm 74 lb.-ft). The installation dimensions and space requirement for service access are shown in the installation drawing (Figure 1). The specified horizontal and axial angles must not be exceeded (Figure 2).

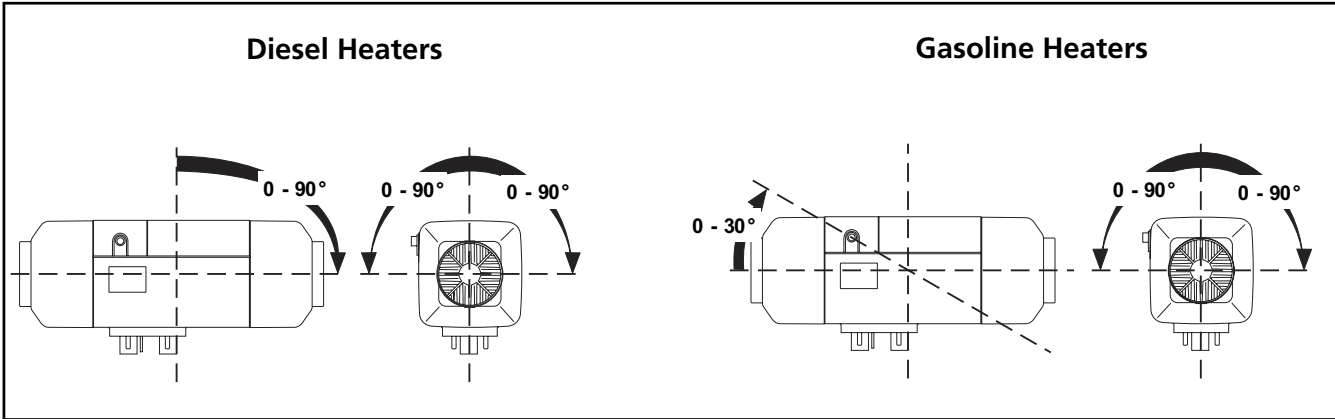

Figure 2. Recommended Installation Positions for AT 3900/5500 Heaters

A seal (Figure 4) **must** be fitted between the heater and the vehicle body. This seal must be replaced each time the heater is installed. The support area for the heater foot must be flat. A special tools can be purchased from Webasto to drill the holes and, if necessary, smooth the support area. The seal can compensate for unevenness of max. 1 mm.



The seal or foam gasket or both must be replaced each time the heater is removed and re-installed.

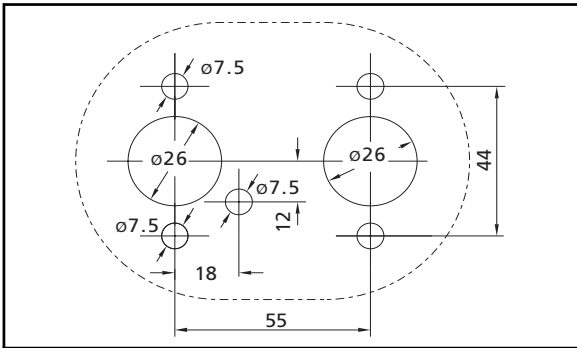

Figure 3. Hole Pattern

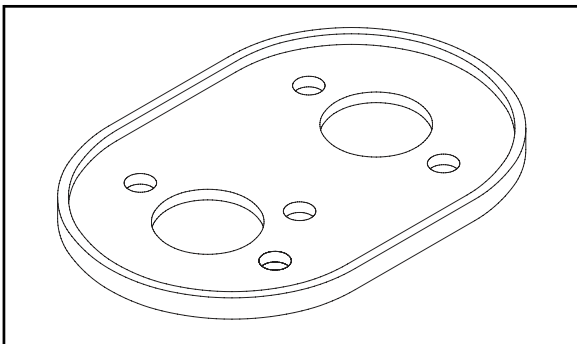

Figure 4. Seal

4.5 Optional Mounting Plate

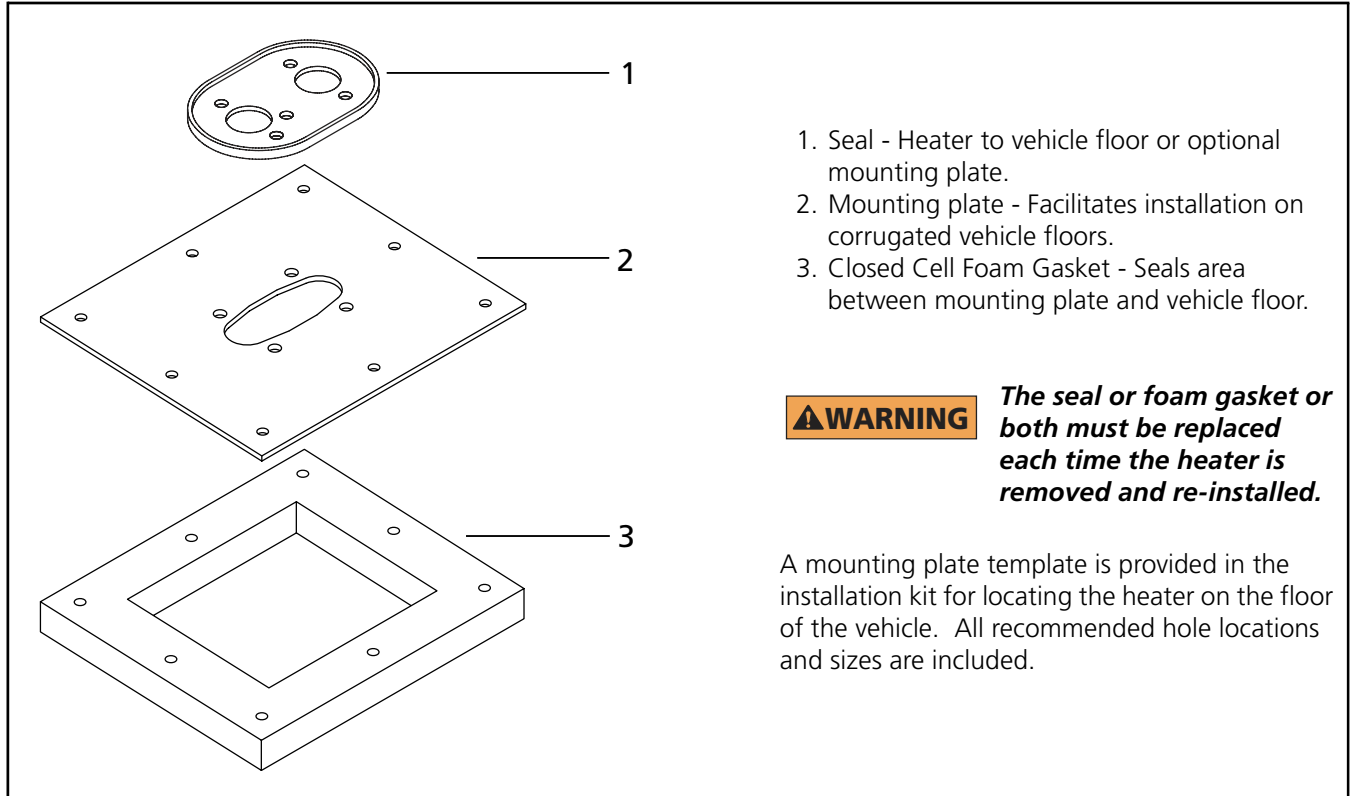

Figure 5. Mounting with optional mounting plate

CAUTION *When using the optional mounting plate and closed cell foam gasket, do not over tighten the mounting bolts. Doing so will cause the mounting plate to warp and result in stress damage to the heater and fan motor.*

IMPORTANT! *After installation, check that the heater casing is not in contact with any parts of the vehicle body. A failure to do this may result in the hot air fan binding internally (Figure 6).*

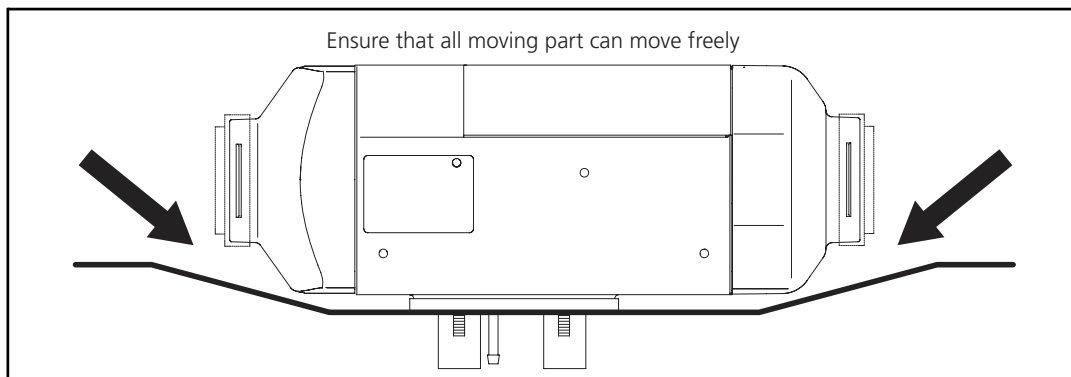

Figure 6. Installation

4.6 Factory Plate / Label

The model/serial number plate of the heater must be positioned so that it cannot be damaged and must be clearly legible when the heater is installed (otherwise a duplicate model plate must be used).

Inapplicable years must be erased from the model plate.

4.7 Installation Example

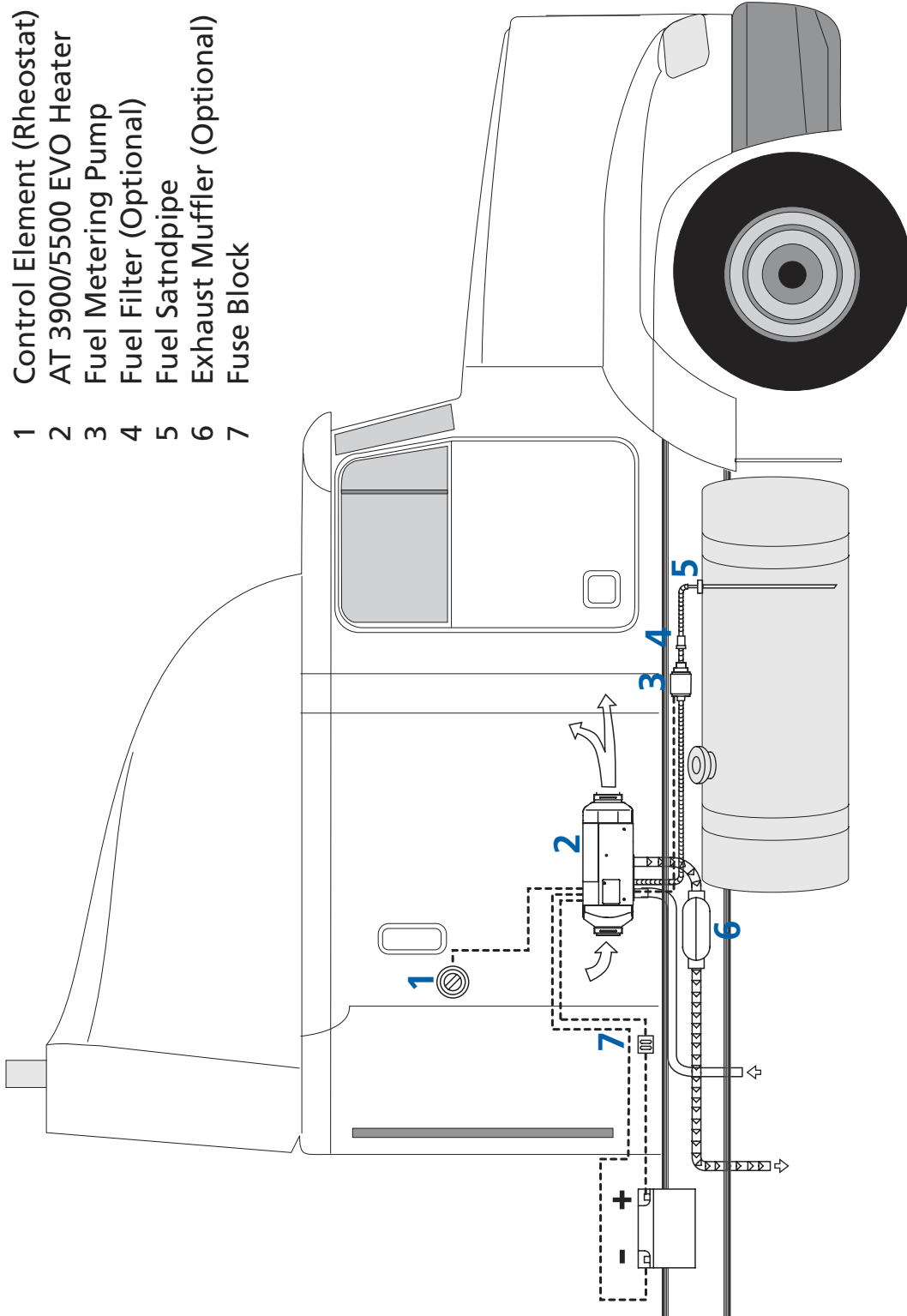

Figure 7. Installation example with heater in stalled under-bunk. (Recirculation mode)

5. Hot Air System

NOTE:

The heater must not be integrated into the vehicle's air system.

Both recirculation and fresh air modes are possible.

For fresh air mode it must be ensured that the inlet (hot) air is taken from an area protected from splashing water and spray and in such a way that no water can ingress into the heater if the vehicle travels through a water hazard for which that vehicle is licensed.

NOTE:

For fresh air mode, an external temperature sensor must be fitted in the appropriate zone. The standard pause speed for the blower motor is 0 rpm if the external temperature sensor is used

Inside the control unit there is a temperature sensor, which operates the heater in the appropriate heat output range in conjunction with the control element depending on the intake temperatures and the position of the set point generator. The heat output is controlled such that after the selected interior temperature has been reached quickly, it is then kept at this selected value.

The internal diameter of the main section of the hot air line should be:

90 mm (3.54 in.) minimum for the Air Top EVO 5500

80 mm (3.14 in.) minimum for the Air Top EVO 3900

NOTE:

Only materials that can permanently withstand temperatures of at least 130°C (266°F) may be used for the hot air line. The hot air opening is to be positioned in such a way that the air is not blown on to any parts that cannot withstand the heat.



IMPORTANT!

In vehicles used to transport people, the air outlet opening is to be directed in such a way that it is at least 20 cm (8 in.) away from all body parts.

Maximum pressure drop between the inlet and outlet side of the hot air line:

Air Top EVO 3900 2.0 hPa

Air Top EVO 5500 3.0 hPa

1 hPa corresponds to 1 mbar corresponds to 10 mm Water Column (0.4 inches Water Column).

The heaters check the internal temperature rise automatically each time they are switched on. If this is above the specified limits (150°C / 302°F), the start is cancelled and error messages F10 (Overheat code) is displayed. To ensure that the heater functions stably, the flow resistance of the connected hot air system must be reduced.

The hot air hose must be secured at its connection points.

If the heater is used in recirculation mode, for example, in the under bunk compartment of a truck's sleeper, without a hot air directional outlet grille, do not short circuit the hot air flow.

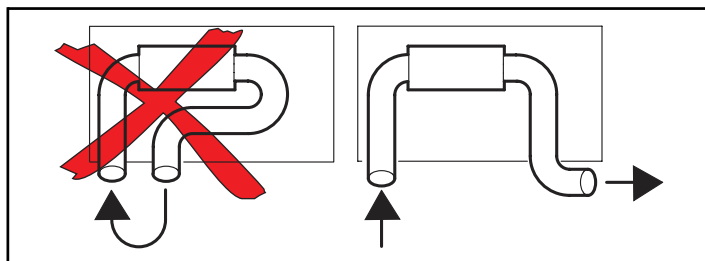

Figure 8. Hot air inlet and hot air outlet (recirculation mode)

**IMPORTANT!**

If you use the heater without a hot air inlet hose, the inlet grille supplied with the heater must be used at all times.

NOTE:

The installation must be checked for:

- Air short circuit between the vehicle's heating system and the heater air inlet.
- Air short circuit between the heater's air inlet and the heater's air outlet (Figure 8).

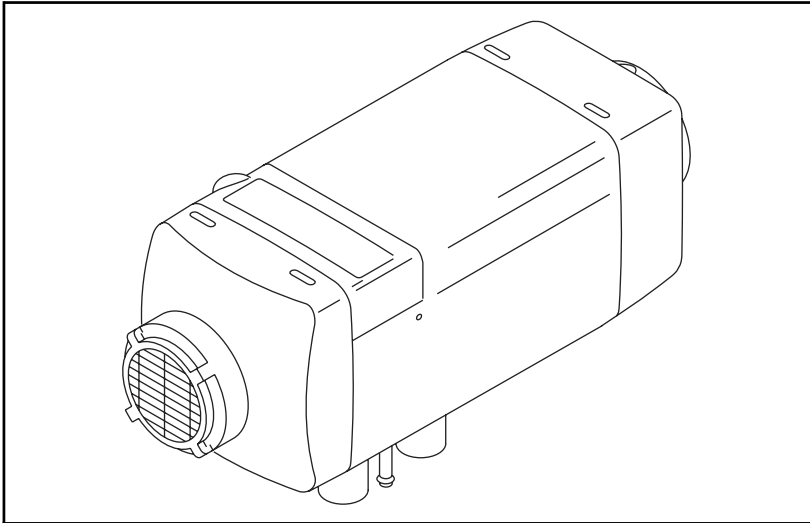

Figure 9. Hot air inlet with inlet grille

If you use an installation box the air vent must be sealed in such a way that no hot air can get into the installation box.

5.1 External Temperature Sensor

The installation of an external temperature sensor is recommended if the heater is operated in fresh air mode.

5.1.1 To Install the External Temperature Sensor

The external temperature sensor must be installed at medium height in the passenger cabin on vertical surfaces if possible in the area that requires heating.

The temperature sensor must **not**

- be in the direct current of hot air (from the vehicle's own heating system or the hot air heater).
- be close to heat sources (for example the vehicle's own heating system).
- be placed in direct sunlight (for example on the dashboard).
- be installed behind curtains or the like.

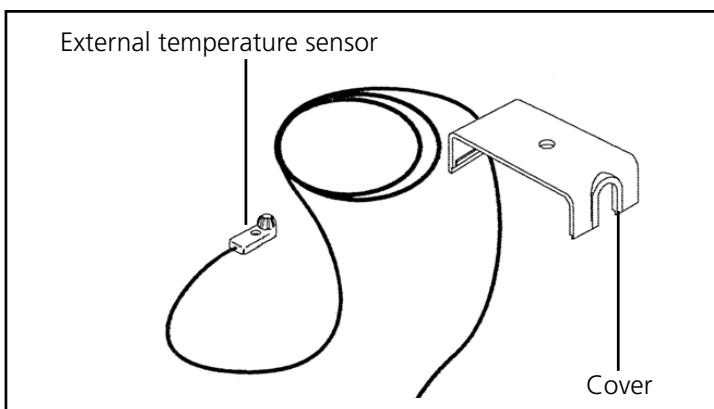

Figure 10. External temperature sensor - optional

6. Fuel Supply

The fuel is taken from the vehicle fuel tank or from a separate fuel tank. The values for the maximum pressure at the fuel extraction point are shown in Figure 11.

Permissible fuel inflow height H	At max. pressure in fuel line
0.00 m (0.00 in.)	0.2 bar (2.9 PSI)
1.00 m (39.4 in.)	0.11 bar (1.6 PSI)
2.00 m (78.7 in.)	0.03 bar (0.44 PSI)
Maximum fuel intake height S	At max. negative pressure in the fuel tank
0.00 m (0.00 in.)	-0.10 bar (-1.45 PSI)
0.50 m (19.7 in.)	-0.06 bar (-0.87 PSI)
1.00 m (39.4 in.)	-0.02 bar (-0.29 PSI)

A sign must be affixed to the fuel tank's filler neck warning that the heater must be switched off before refuelling.

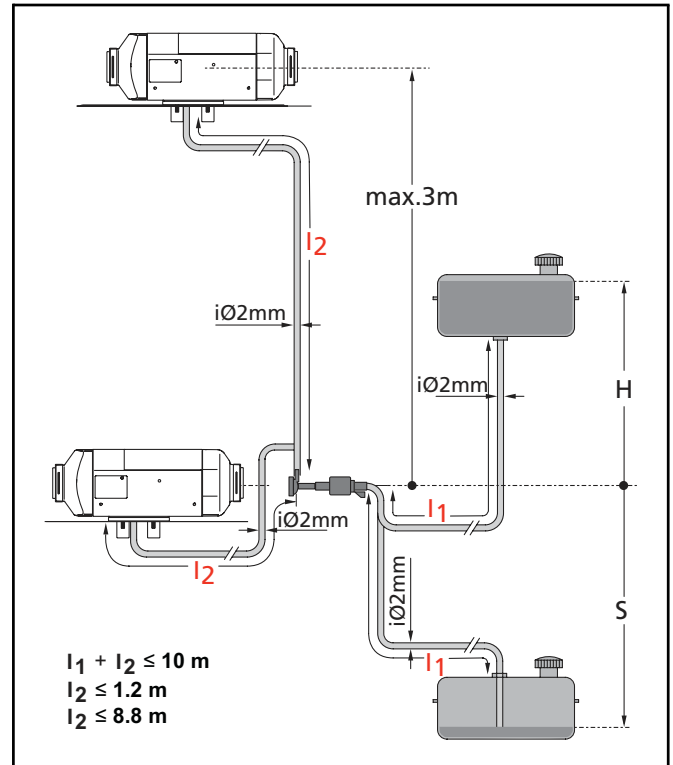

Figure 11. Fuel supply

6.1 Vehicles with a Carburetor Equipped Engine

The fuel may only be extracted using the special Webasto fuel extractor (see Figure 12) as close to the tank as possible. The connection may be made in either the supply or return line, in which case the return line must lead almost to the base of the tank (see Figure 13).

The fuel extractor must be fitted in such a way that any air or gas bubbles are automatically discharged towards the tank (see Figure 12).

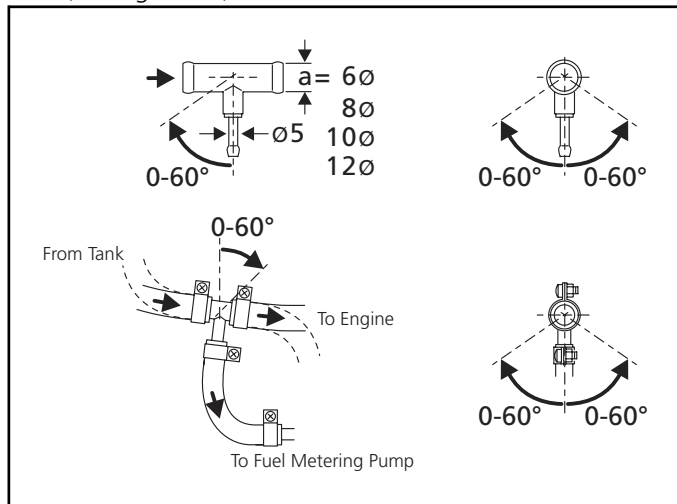

Figure 12. Webasto fuel extractor

The fuel extractor should not be located near the engine, as gas bubbles may form in the lines on account of heat radiated from the engine. This may cause problems during combustion.

6.2 Vehicles with Fuel Injection Engines

When installing the heater in a vehicle with fuel injection system, it is important to establish whether the fuel pump is located inside or outside the tank.

If the fuel pump is located inside the tank, fuel can only be extracted from the return line using the Webasto fuel extractor (see Figure 12), in which case it must be ensured that the return line continues almost to the bottom of the tank (see Figure 13 for details of the minimum distance from the bottom of the tank). If this is not the case Webasto fuel extractors or standpipes (see Figures 13, 14 and 15) may be used.

If the fuel pump is installed outside the tank, the fuel connection may also be made between the tank and the fuel pump, again using only the Webasto fuel extractor (see Figure 12).

6.3 Vehicles with Diesel Engines

The fuel must be taken from the vehicle fuel tank or from a separate tank (see Figs. 13, 14 and 15). This separate fuel pickup precludes any effect of pressure.

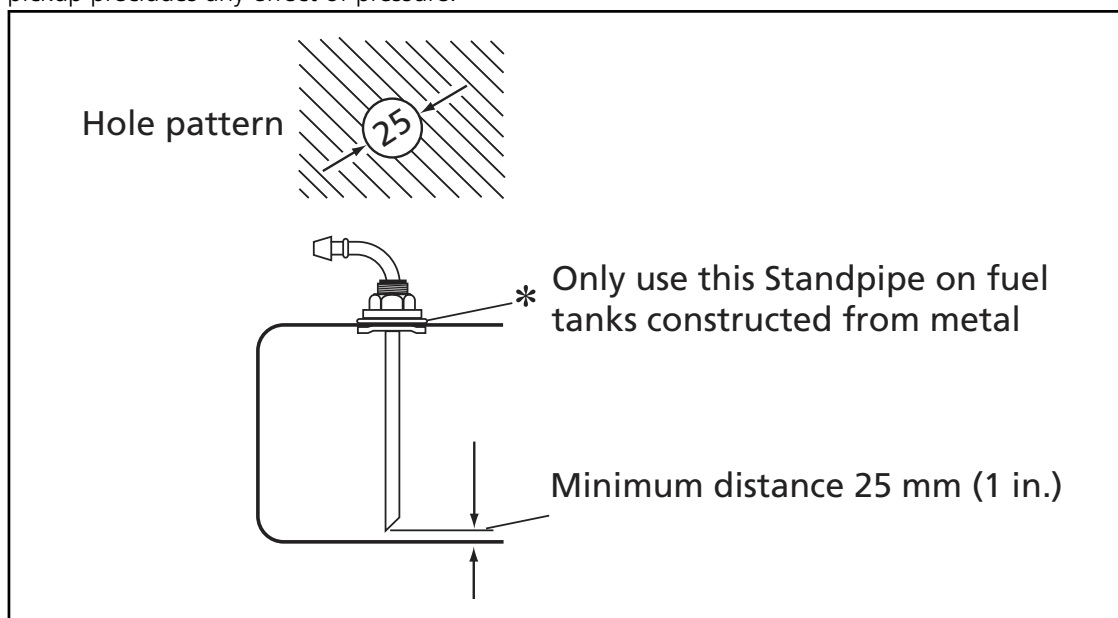

Figure 13. Webasto fuel standpipe

NOTE:

The tank fitting must be made from metal!

6.4 Fuel Lines

Only steel, copper and plastic lines of plasticized, light and temperature-stabilized PA 11 or PA 12 (e.g. Mecanyl RWTL) pursuant to DIN 73378 may be used for the fuel lines.

Since the lines normally cannot be routed with a constant rising gradient, the internal diameter must not be allowed to exceed a certain size. Air or gas bubbles will accumulate in lines with an internal diameter of more than 2 mm and these will cause malfunctions whilst the heater is operating if the lines sag or are routed downwards. The diameters specified in Figure 11 will ensure that bubbles do not form.

The lines should not be routed downwards from the metering pump to the heater.

Unsupported fuel lines must be secured to prevent them from sagging. They must be installed in such a way that they cannot be damaged by flying road debris and high temperatures (exhaust line).

The fuel lines must be secure at the connections using hose clamps to prevent their slipping.

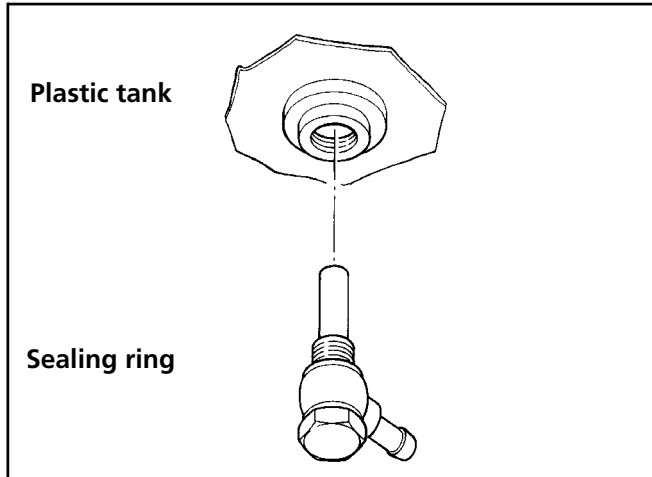

Figure 14. Fuel supply from plastic tank drain screw

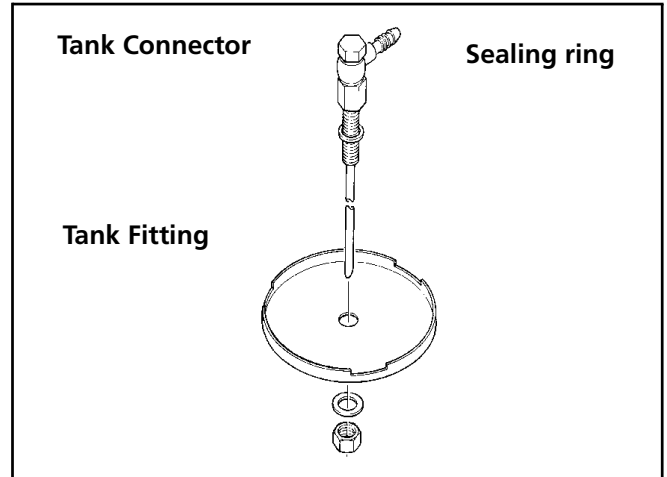

Figure 15. Fuel supply from plastic tank fitting

6.4.1 Connecting Two Fuel Lines with a Coupler Hose

The correct procedure for connecting fuel lines with hosing is shown in Figure 16. Ensure that there are no leaks.

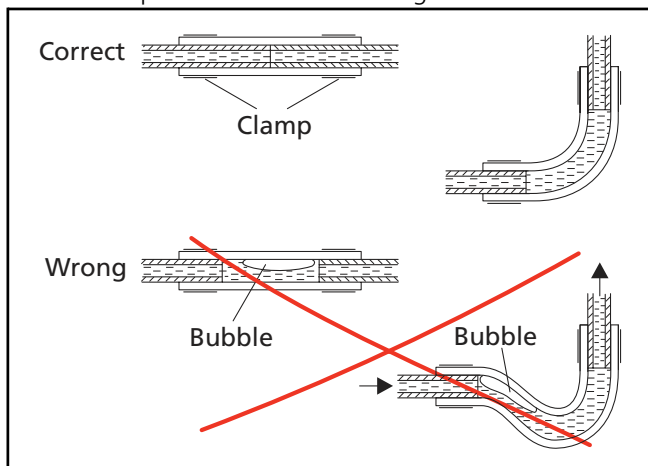

Figure 16. Fuel line / coupler hose connection

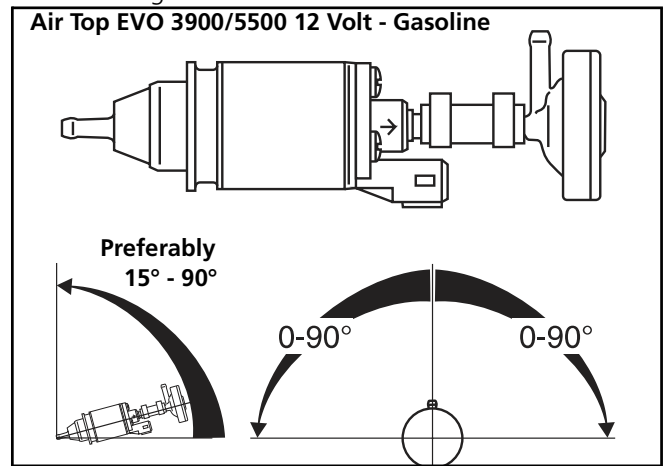

Figure 17. Fuel Metering Pump DP 2

6.5 Fuel Metering Pump

The fuel metering pump is a combined delivery, metering and shut-off system and is subject to certain installation criteria (see Figures 11 and 18).

6.5.1 Installation Location

It is advisable to install the metering pump in a cool place. The maximum ambient temperature must not exceed +20 °C (68 °F) for gasoline heaters at any time during operation.

The metering pump and fuel lines must not be installed within range of the radiated heat from hot vehicle parts. A heat shield must be used if necessary

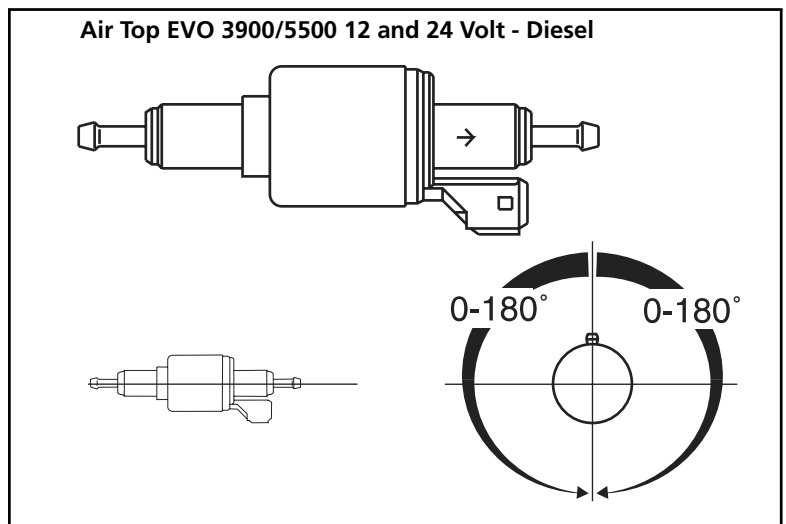

Figure 18. Fuel metering pump DP 30.2 / 30.3

6.5.2 Installation and Attachment

The metering pump must be secured with a vibration-damping mounting. Its installation position is limited as shown in Figure 18 in order to ensure effective automatic bleeding.

As a result of the risk of corrosion, only genuine Webasto parts may be used for the plug connections between the metering pump and the metering pump wiring harness.

6.6 Fuel Filter

Only a Webasto filter is allowed to be used if the fuel is expected to be contaminated. Install vertically if possible, however at least horizontally (check flow direction).



IMPORTANT!

Do not substitute the Webasto supplied fuel filter with a non Webasto replacement. Irregular heater operation may result.

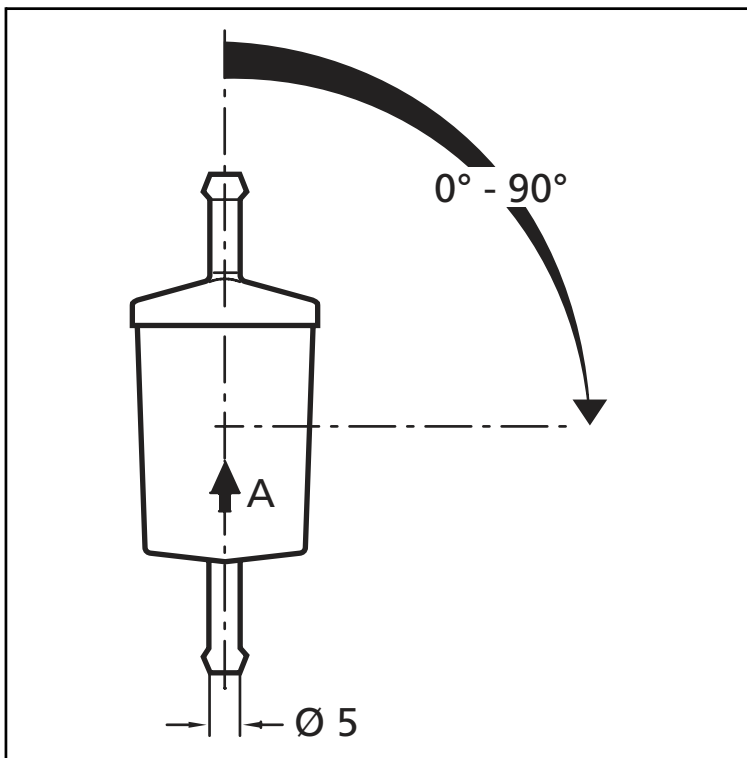

Figure 19. Fuel filter

7. Combustion Air Supply

Under no circumstances may the combustion air be taken from areas occupied by people. The combustion air intake opening must not point in the direction of travel. It must be located so that it cannot become clogged with dirt and road debris.

NOTE:

An intake silencer must be fitted if the intake hose length is greater than 0.6 m (24 in.).

NOTE:

The combustion air must be extracted using a combustion air line from a position that is as cool as possible and protected from splashing water.

Do not use an exhaust line as the combustion air line since otherwise the metering pump cable from the combustion air inlet port may be damaged.

The combustion air opening must not be under the minimum water drive-through level permitted for the vehicle.

See the regulations for the installation for further regulations.

8. Exhaust Pipe

Rigid pipes of unalloyed or alloyed steel with a minimum wall thickness of 1.0 mm (3/64 in.) or flexible piping of alloyed steel only must be used as exhaust line.

The exhaust pipe is secured to the heater using a clamping collar, for example. See the 'regulations for installation' for other requirements.

The exhaust muffler should ideally be installed near the heater. The heater may also be operated without a muffler.

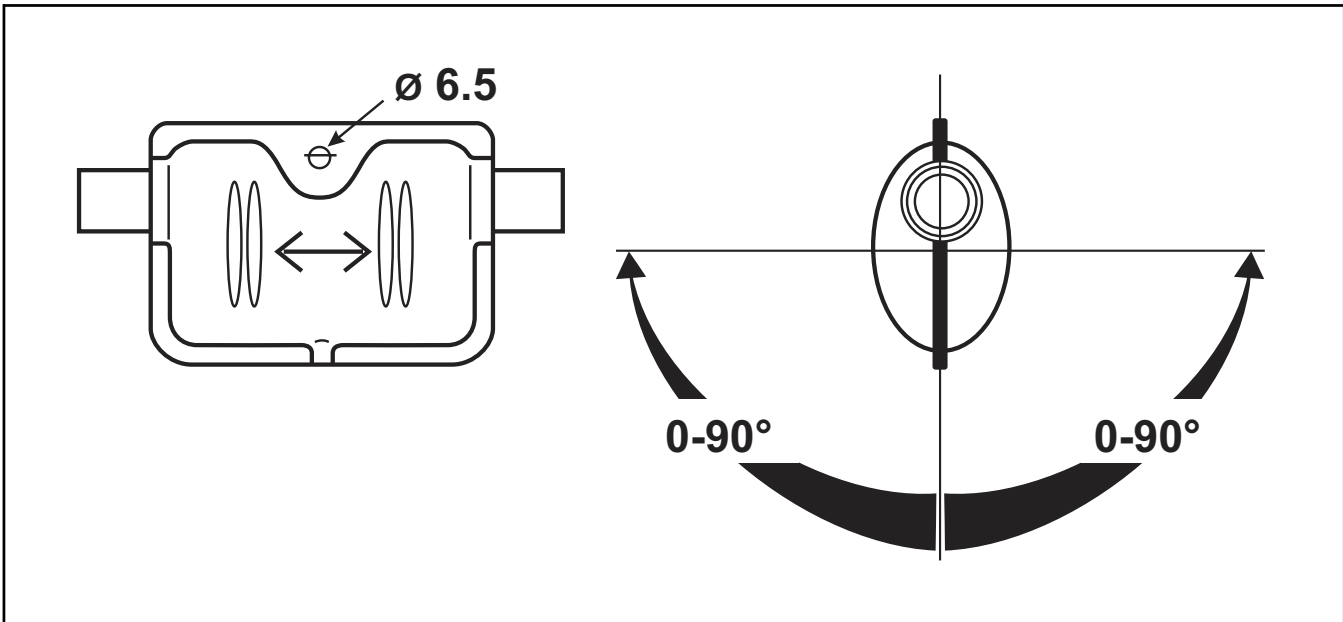

Figure 20. Exhaust muffler - exhaust flow is non-directional (arbitrary)

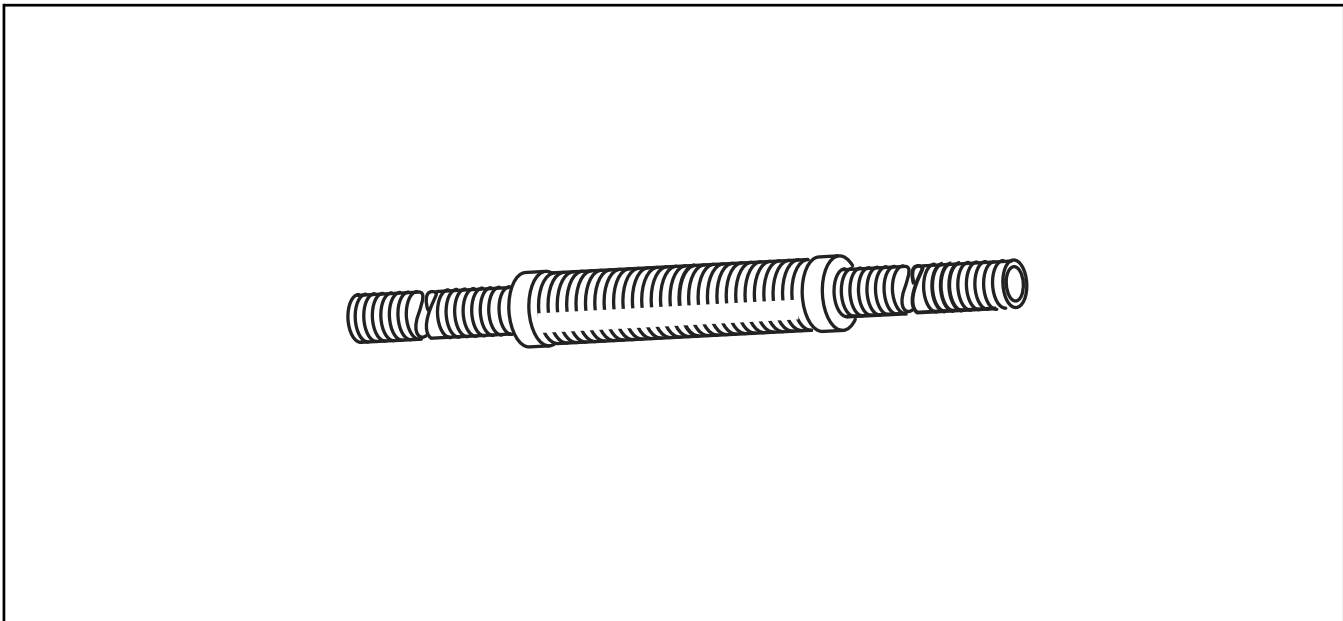

Figure 21. Exhaust silencer for boat applications - Flow direction and installation position is non-directional (arbitrary)

9. Combustion Air Inlet and Exhaust Lines

Both lines are to be installed falling away from the heater. If this is not possible, a condensate drain hole with a diameter of 4 mm (5/32 in.) must be made at its lowest point.

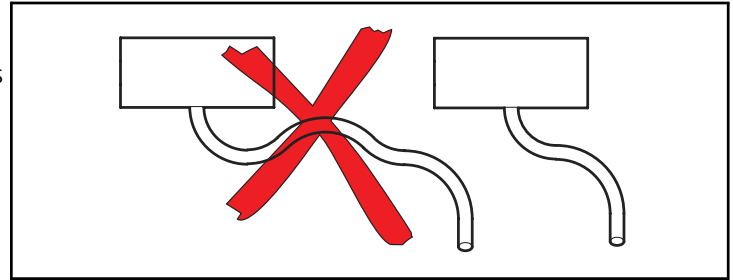

Figure 22. Prevent the formation of condensate

The lines must not point to the front of the vehicle.

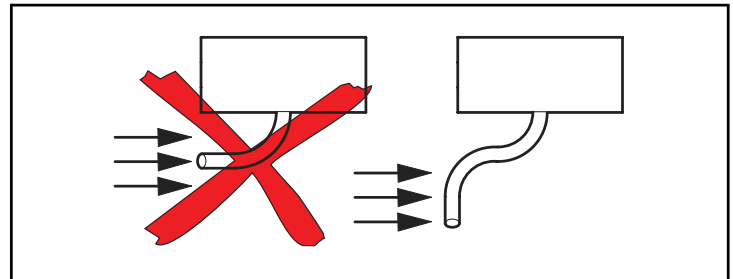

Figure 23. Lines must not point in the direction of travel

The lines must be located so that they cannot become clogged with dirt and road debris.

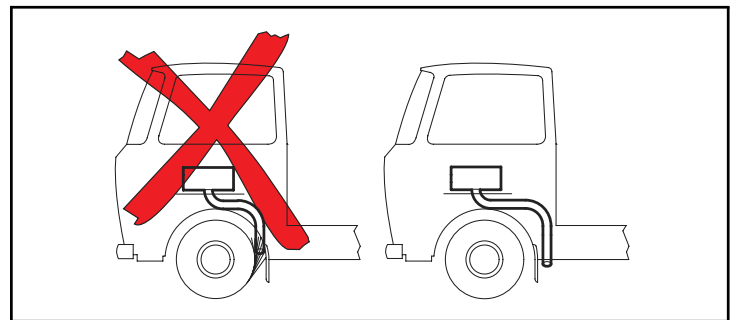

Figure 24. Avoid the lines becoming clogged with dirt

Length of the combustion air inlet and exhaust lines in total:

- With muffler: max. 2.0 m
- Without muffler: max. 5.0 m

NOTE:

If the exhaust line is over 2 m in length the lines must be insulated (to prevent falling below the dewpoint)

Internal diameter of the lines:

- Combustion air line: 24 mm
- exhaust line (metal): 24 mm

Minimum bending radius: 50 mm

Total bends:

- Combustion air line: max. 270°
- Exhaust line: max. 270°.

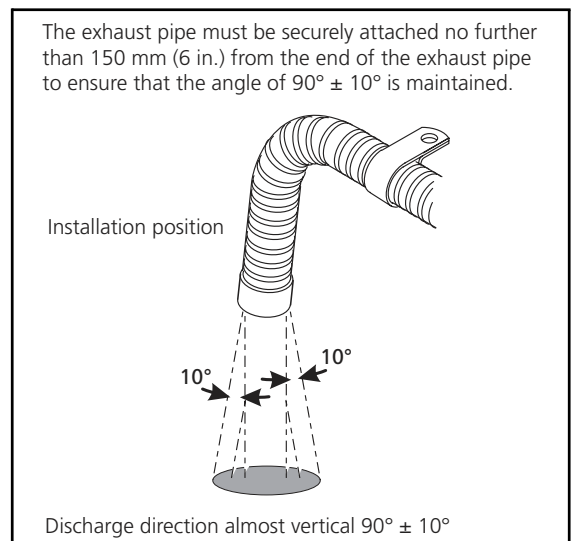

Figure 25. Exhaust pipe opening

IMPORTANT!

If the exhaust pipe ends other than as shown in Figure 25, it will pose a fire risk.

10. Electrical Connections

All the cables and wires that are not required must be insulated against accidental shorting or grounding.

NOTE:

The electrical connection is made as shown in the system circuit diagram (Figure 35).

10.1 Heater Connection

To connect the wiring harness, remove the control unit cover on the heater and connect the wiring harness plug to the control unit.

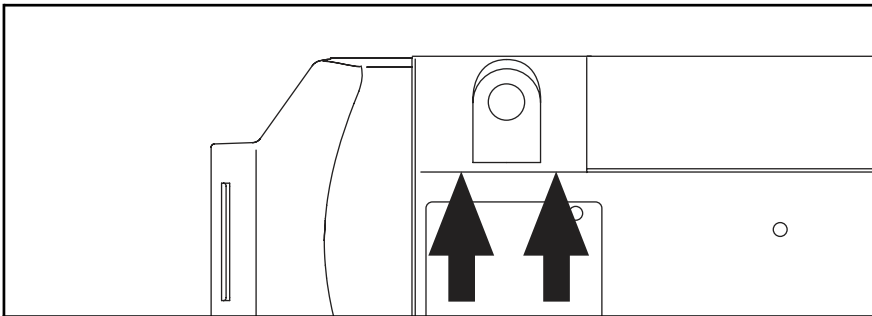

Figure 26. To remove the control unit cover

NOTE:

Raise the control unit cover on both sides using a blunt blade (Figure 26 arrows).

Before using the heater for the first time, fit the control unit cover in place on the heater to prevent the escape of hot air (heater overheating).

The cable passage of the cover can be placed at either the left or right side.

To ensure that the cable passage in the control unit cover seals perfectly, the cable grommet is to be adjusted appropriately on the wiring harness.

10.2 Supply Voltage Connection

Ideally from the vehicle’s central electrical system or at the batteries.

A weather sealed fuse holder is to be fitted to protect the heater (supplied with the heater harness).

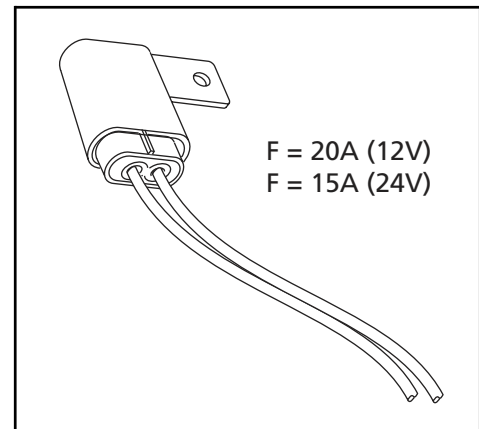

Figure 27. Fuse holder - weather sealed



IMPORTANT!

The Air Top EVO 3900/5500 requires 6.25 amps @ 12 volts or 12.5 amps @ 24 volts during start-up. The main power connection has to be made at a circuit designed to sustain this load without voltage drop. Cigar lighter sockets and auxiliary power outputs for C.B. radio’s and other electronic accessories are not considered adequate power supplies for the Air Top EVO 3900/5500.

10.3 Control Element (Rheostat) Connection

The wiring harness is prepared for connection to the control element.

Simply pull on the connector housing to unplug the connector.

The connector housing can be locked (self-locking action) by simply pulling on the wiring harness.

Locate the control element in a convenient location. The control element is not affected by temperature. Temperature is monitored inside the heater or via an optional external temperature sensor (see Figure 31).

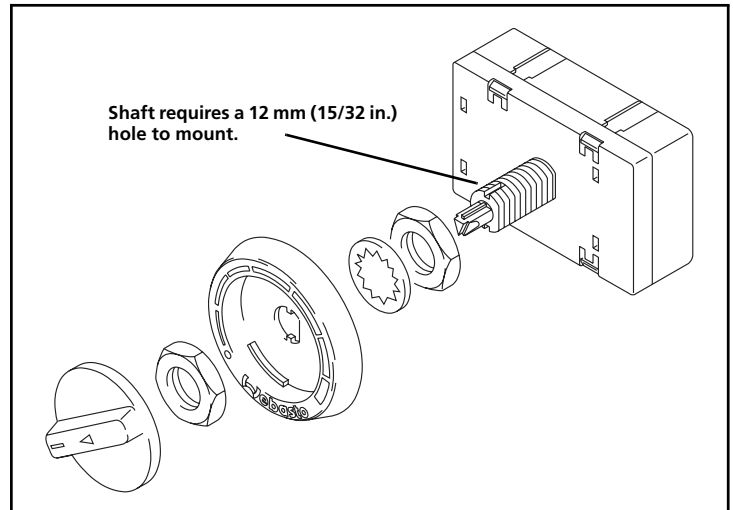

Figure 28. Control element (rheostat)

NOTE:

The fibre optic lens must be in contact with the rotary knob.

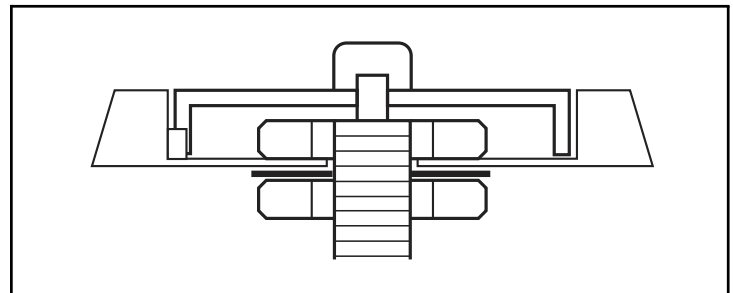

Figure 29. Installation of the control element - correct

NOTE:

The rotary knob must sit flush with the bezel (Figure 29) not above it as illustrated in Figure 30.

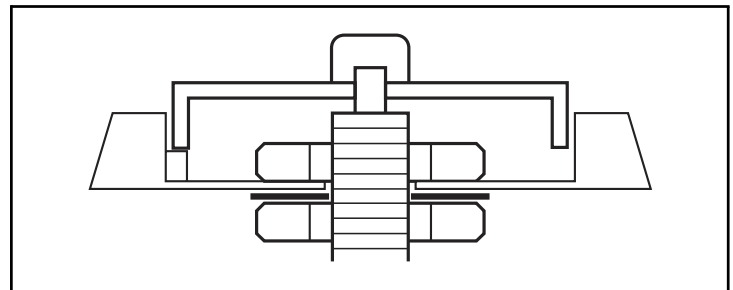

Figure 30. Installation of the control element - incorrect

NOTE:

As an option an external temperature sensor may be installed in the passenger cabin (see page 12).

See installation instructions included with the sensor or see the service instructions in the Workshop manual for further information.

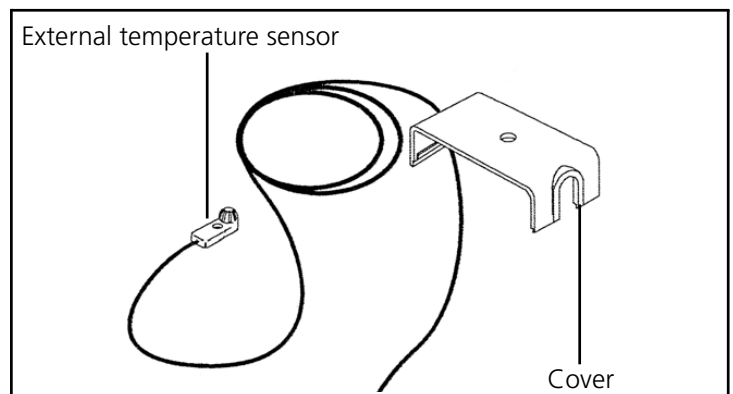

Figure 31. External temperature sensor - optional

10.4 Installation Instructions for Control Panel MC04/05

The Control Panel should be installed in a suitable location (on a flat surface if possible) in the area visible to the driver.

- Use Drilling Template for Control Panel MC04/05 for cut-out and holes (see "Drilling templates")
- Connect Control Panel to existing connectors on heater-unit wiring harness (see "Connection diagram/Circuit diagram")
- Pre-mount control unit in cut-out
- Lightly press fastening screws into holes and screw in
- Carefully clip on trim frame

NOTES:

- Control Panel is only intended for installation in passenger compartment
- Ensure good readability when selecting installation location
- Observe information on adhesive labels and colored markings when connecting Control Panel to vehicle wiring harness

Figure 32. Installing Control Panel MC04/05

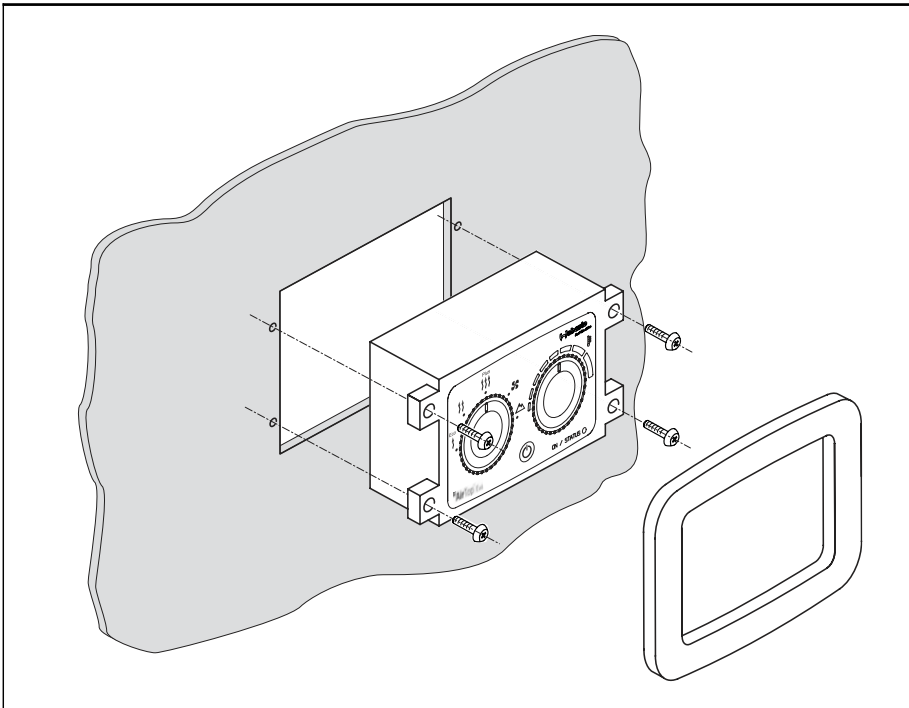

10.4.1 MC04/05 Control Panel Connections

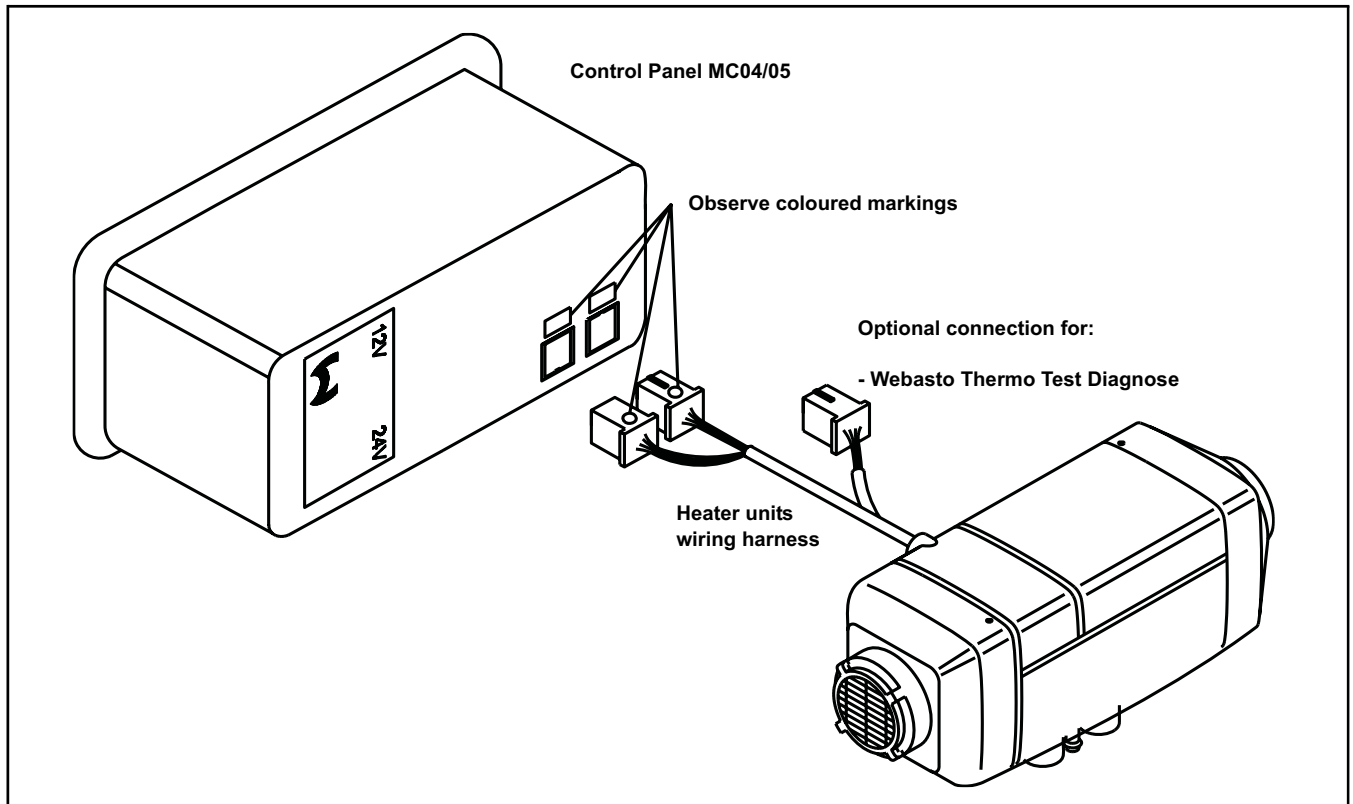

Figure 33. Connection Diagram for Air Top EVO 3900/5500 with Control Panel MC04/05

10.4.2 Combination Timer 1531 Connections

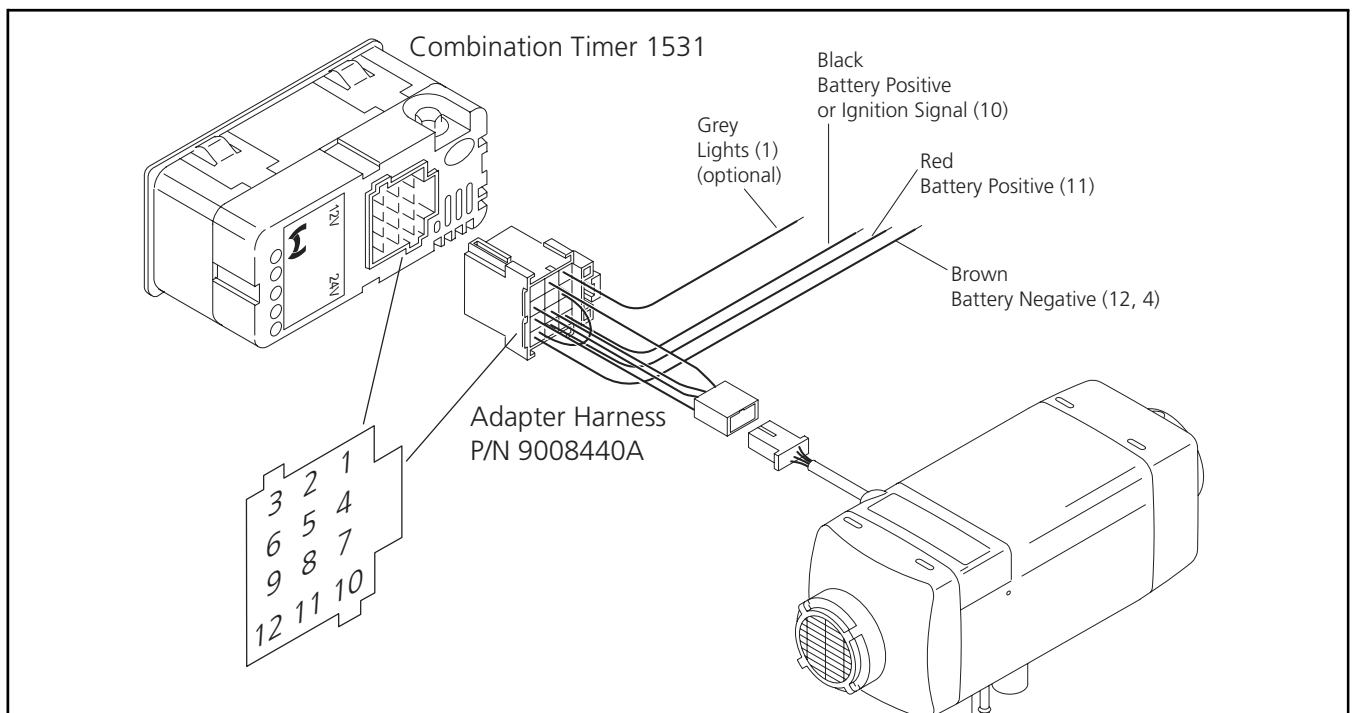

Figure 34. Air Top EVO 3900/5500 with combination timer 1531 - connection diagram

11. Circuit Diagrams

11.1 Legend for Circuit Diagrams

Cable colors (where applicable)	
bl	blue
br	brown
ge	yellow
gn	green
gr	grey
or	orange
rt	red
sw	black
vi	violet
ws	white

Item	Description	Comment
A1	Heater	Air Top EVO 3900/5500
A2	Control module	
B2	Temperature sensor	Internal
B3	Overheating sensor	Overheating guard
B4	Temperature sensor	External
E	Ceramic glow pin	
F1	Fuse 24 V 15 A/12 V 20 A	Flat fuse SAE J 1284
F2	Fuse 20 A	Flat fuse SAE J 1284
F3	Fuse 15 A	Flat fuse SAE J 1284
H1	LED, green (in item S1)	Indicator
H3	LED red (in item P)	Light in immediate heat button, ready indicator, Switch-on indicator
H4	Heating symbol in the display (item P)	Indicator
H5	Light (in item P)	Display and button lights
H6	Light (at least 1.2 W)	Switch-on indicator pumping device
K	Relay with free wheeling diode	for vehicle fan
M1	Motor	Combustion and hot air fan
M3	Motor	Vehicle fan
P	Combination Timer (1531)	Timer and setpoint generator
R1	Resistor 620 Ohm	With internal temperature sensor only
S1	Control element	Set point generator switch
S2	1 or 2 pin disconnecting switch	Emergency Stop switch
S3	Switch	On and for pumping device
S5	Switch	CO ₂ setting
S6	Switch	Ventilation or boost
S7	Momentary contact switch	Immediate heat button remote control
S8	Battery isolation switch	
V1	Diode	
V12	Diode	
X1	Plug connector, 2-pin	To item A2 (B)
X2	Plug connector, 2-pin	To item A2 (V)
X3	Plug connector, 2-pin	To item A2 (U)
X4	Plug connector, 2-pin	To item A2 (Z)
X5	Plug connector, 2-pin	To item A2 (Y)
X6	Plug connector, 2-pin	To item A2 (X)
X7	12-pin plug connection	To item A2 (1)
X8	Plug connector, 2-pin	
X9	Plug connector, 4-pin	To item S1
X10	Plug connector, 2-pin	
X11	Plug connector, 2-pin	To item Y1
X12	12-pin plug connection	To item P
Y1	Metering pump	
Y2	Solenoid valve	for pumping device

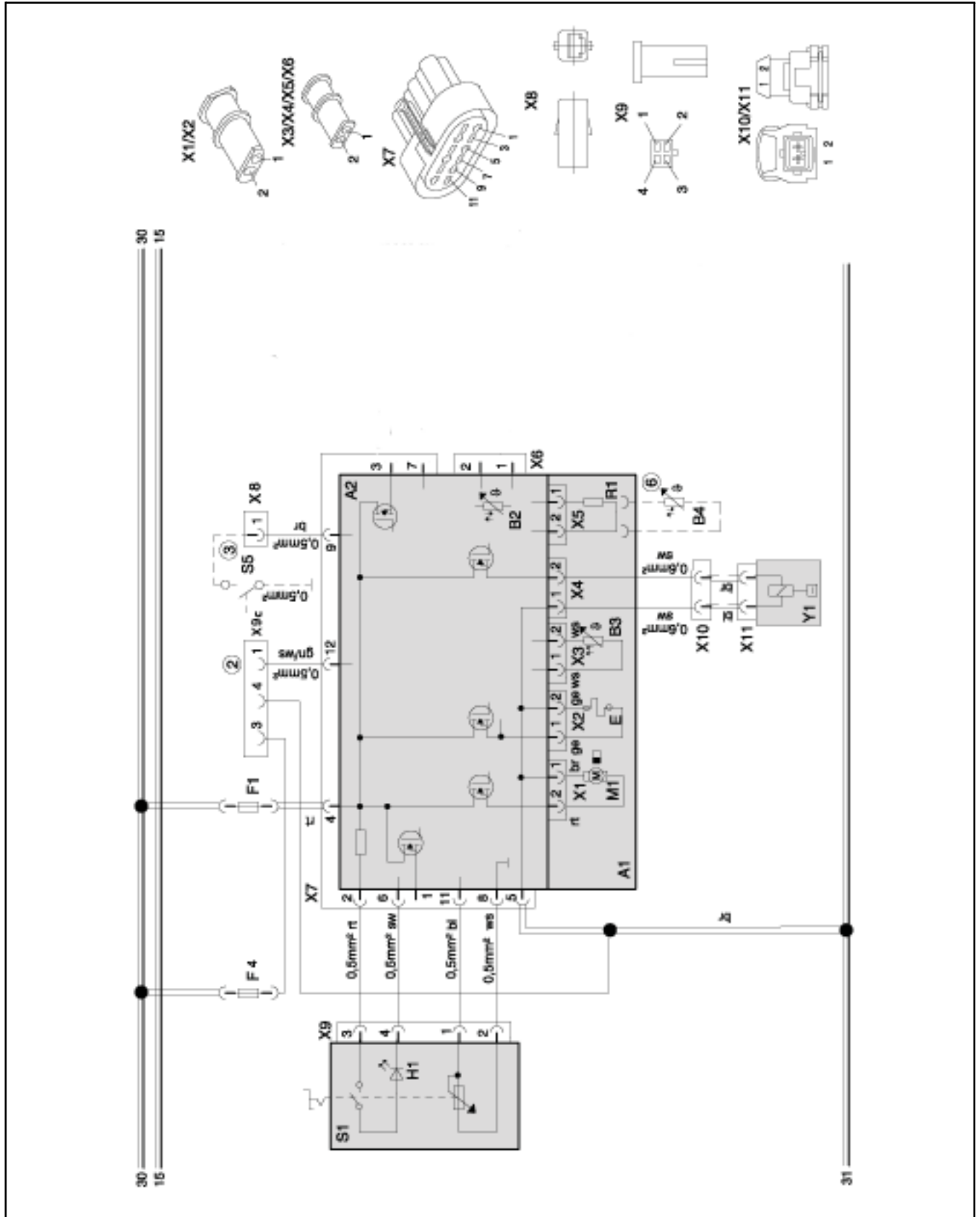

Figure 35. Standard system wiring diagram for the Air Top EVO 3900/5500, 12 / 24 Volt with control element.

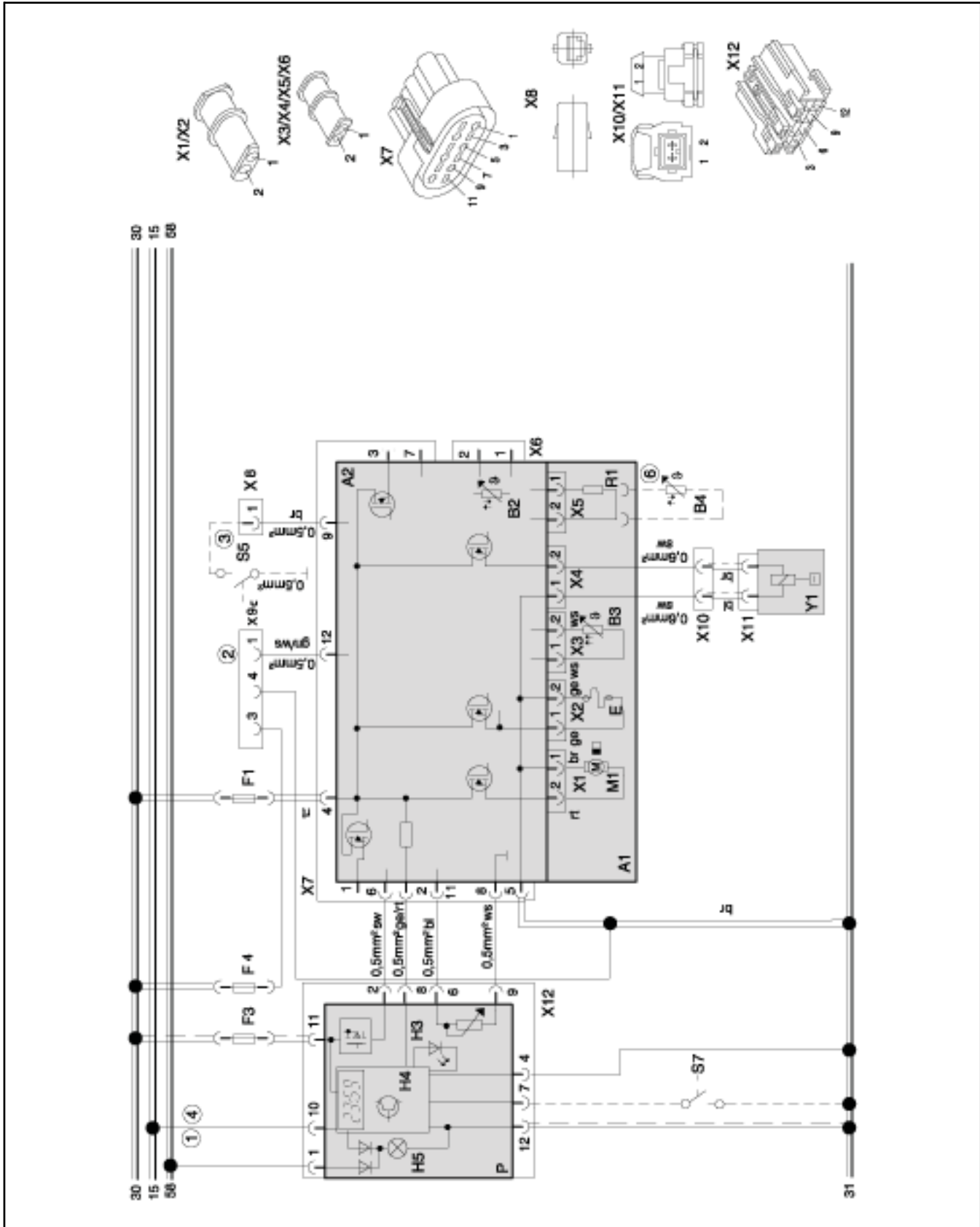

Figure 36. Standard system wiring diagram for the Air Top EVO 3900/5500, 12 / 24 Volt with combination timer.

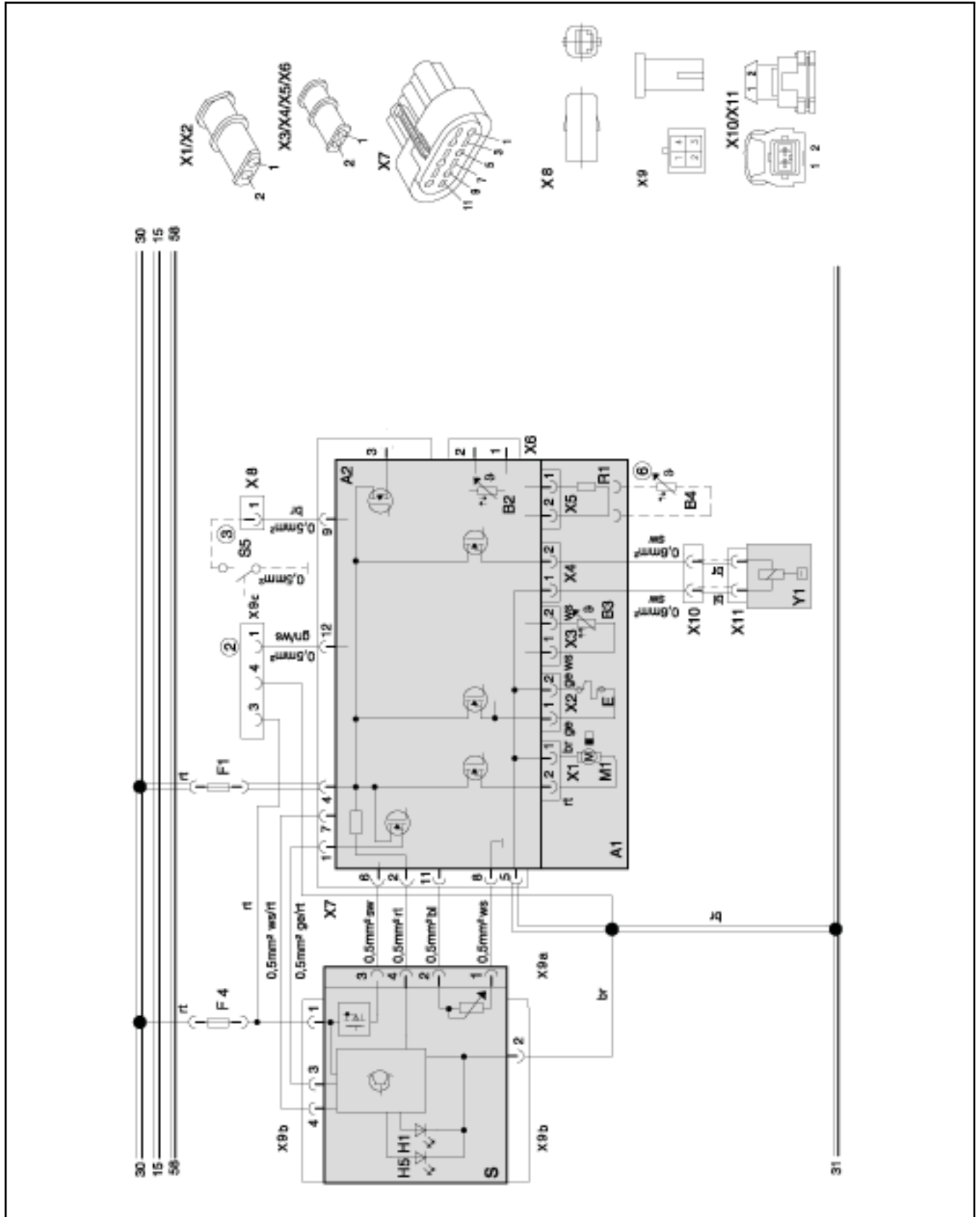

Figure 37. Standard system wiring diagram for the Air Top EVO 3900/5500, 12 / 24 Volt with control panel MC04/05.

12. Starting the Heater for the First Time

After you have installed the heater, bleed the fuel supply system carefully.

NOTE:

As a result of the low fuel consumption the heater must be switched on several times to fill the fuel line and prime the system.

Conduct a trial of the heater to check all the connections for leaks and to ensure that they are secure. If the heater suffers a fault during operation, the fault must be located and remedied.

12.1 Control Element Description

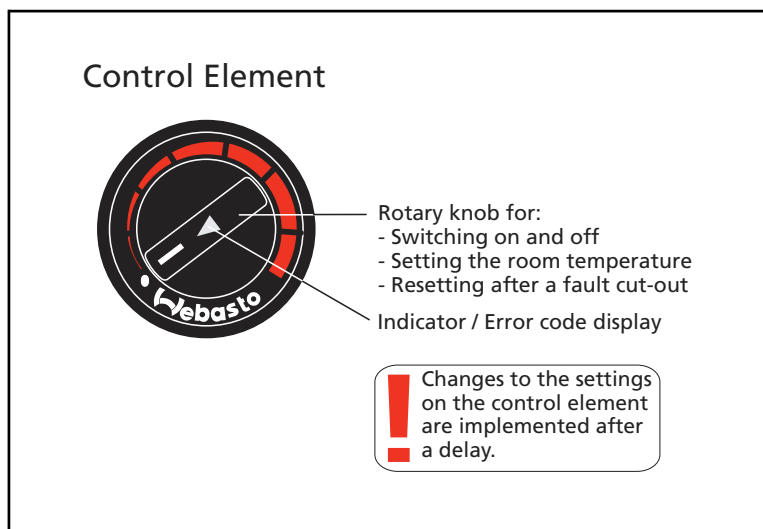

Figure 38. Control element

12.2 Ventilation Mode (Optional Connection)

Where desired, a separate switch installed between the white/red tracer or pink wire (X7, Pin-7) and a ground point allows the user to choose between heating and ventilation mode. Refer to Figure 35, item S6 for connection detail. In ventilation mode (switch S6 'On') the fan speed is regulated by the control element knob.

13. Fault Lock-out

The control unit continuously monitors the heater operation. The control unit identifies errors on individual heater components and faults during operation. Should the control unit experience component errors and operational faults, the heater will be shut down.

The heater is shut down (fault lock-out) if:

- No or incorrect start
- Temperature sensor defective
- Overheating sensor interrupt or short circuit
- Overheating sensor installed incorrectly
- Ceramic glow pin interrupt or short circuit
- Fan motor overload or blocked or short circuit or interrupt
- Error in the fuel metering pump or overheating guard circuit (start phase only)
- Under voltage less than 10 V or over voltage greater than 15 V and for longer than 20 seconds (on 12 V heater)
- Under voltage less than 20 V or over voltage greater than 32 V and for longer than 20 seconds (on 24 V heater)
- Control unit defective
- Overheating

The fuel supply is stopped if the heater overheats.

The heater continues to run in the same way as if it is switched off manually.

After the heater stops the control unit will be set to fault lock-out.

Overheating is indicated by the indicator flashing 10 times.

Rectify the cause of the fault.

To reset the fault, switch the heater on and off briefly (at least 2 seconds).

If serious faults, such as overheating or no start, occur frequently, the heater will be set to fault lock-out (F 12) and can be restarted by disconnecting the supply voltage (e.g. removing the fuse).

13.1 Error Code Output

NOTE:

An error code is generated on the control element indicator light after an error has occurred. When determining the generated code, there will be a series of 5 fast flashes after which, the error code will be generated by a sequence of long flash pulses, count only the long flash pulses to obtain the code. Error codes are shown in the table below.

If the heater is fitted with a combination timer, an error message will appear on the display of the timer after a fault occurs. If the control element is used, the error number is indicated by the indicator light flashing:

F 00	Control unit error / incorrect parameter set / warm start recognition
F 01	No start (after 2 attempts to start) / no flame formation
F 02	Flame failure (repeated more than 3 times)
F 03	Under voltage or over voltage
F 04	Premature flame recognition
F 06	Temperature sensor interrupt or short circuit
F 07	Metering pump interrupt or pump short circuit
F 08	Fan motor interrupt or short circuit or overload or blocked
F 09	Ceramic glow pin interrupt or short circuit
F 10	Overheating: Resulting in permanent heater fault lock-out
F 11	Overheating sensor interrupt or short circuit
F 12	Heater lock-out
F 13	Heater lock-out permanent
F 14	Overheating sensor incorrect position
F 15	Set point generator interrupt

14. Technical Data

Except where limit values are specified, the technical data refer to the usual heater tolerances of $\pm 10\%$ at an ambient temperature of $+20\text{ }^\circ\text{C}$ ($68\text{ }^\circ\text{F}$) and at the rated voltage and in rated conditions.

14.1 Electrical Components:

Control unit, motor, metering pump, lamp in the timer and ceramic glow pin / flame monitor are designed for either 12 or 24 Volt.

14.2 Fuel for Air Top EVO 3900/5500 B (Gasoline):

The fuel specified by the vehicle manufacturer must be used.

14.3 Fuel for Air Top EVO 3900/5500 D (Diesel/Heating Oil):

The diesel fuel specified by the vehicle manufacturer must be used. Heating oil may also be used as long as it complies to the normal quality available on the North American market.

We know of no negative influences due to additives.

If fuel is extracted from the vehicle's tank, follow the additive instructions issued by the vehicle manufacturer.

If you change to low-temperature fuel, the heater must be operated for approx. 20 minutes so that the fuel system is filled with the new fuel.

The Air Top EVO 3900/5500 heater is also licensed for use with PME (bio-diesel), which complies with DIN EN 14214.

Heater	Operation	Air Top EVO 3900/5500 B	Air Top EVO 3900/5500 D
Type test permit	EMC Heater	e1*72/245*95/54*1221*00 e1*2001/56*0021*00 e1*2001/56*0020*00	
Model		Air heater with evaporator burner	
Heat output	Control range	1.7 - 3.9 (5.5) kW (5800 - 13307 Btu)	1.5 - 3.9 (5.5) kW (5118 - 13307 Btu)
Fuel		Gasoline	Diesel/PME
Fuel consumption	Control range	0.17 - 0.39 (0.57) kg/h 0.19 - 0.46 (0.73) l/h	0.15 - 0.39 (0.55) kg/h 0.18 - 0.47 (0.66) l/h
Rated voltage		12 V	12 / 24 V
Operating voltage range		10.5 - 16 V	10.5 - 16 /21 - 32 Volt
Rated power consumption	Control range	15 - 45 (116) W	
Max. ambient temperature: Heater: Metering pump Control element	- Operation - Storage - Operation - Storage - Operation - Storage	-40... +40 $^\circ\text{C}$ (-40... +104 $^\circ\text{F}$) -40... +85 $^\circ\text{C}$ (-40... +185 $^\circ\text{F}$) -40... +20 $^\circ\text{C}$ (-40... +68 $^\circ\text{F}$) -40... +85 $^\circ\text{C}$ (-40... +185 $^\circ\text{F}$) -40... +75 $^\circ\text{C}$ (-40... +167 $^\circ\text{F}$) -40... +85 $^\circ\text{C}$ (-40... +185 $^\circ\text{F}$)	
Maximum combustion air inlet temperature		-40... +20 $^\circ\text{C}$ (-40... +68 $^\circ\text{F}$)	
Adjustment range for interior temperature	Control range	+5... +35 $^\circ\text{C}$ (+41... +95 $^\circ\text{F}$)	
Delivery rate for hot air at fan speed	Against 0.5 mbar	max. 132 (200) m ³ /h at 3900 (5500) rpm	
CO ₂ in the exhaust fumes (normal function range)	1 kW 2 kW	1.7 kW: 5.0 - 8.0% 3.5/5.0 kW: 9.0 - 12.5%	1.5 kW: 5.0 - 8.0% 3.5/5.0 kW: 9.0 - 12.5%
Heater dimensions		Length 423 \pm 2 mm (16.65 \pm 0.08 in.) Width 148 \pm 1 mm (5.82 \pm 0.04 in.) Height 162 \pm 1 mm (6.37 \pm 0.04 in.)	
Weight		5.9 kg (13 lb)	

15. Version

Air Top EVO 3900/5500 B (Gasoline)

Air heater for gasoline (12 V)

Air Top EVO 3900/5500 D (Diesel)

Air heater for Diesel/heating oil (12 or 24 V)

16. Drilling Template

Figure 39. Drilling Template for Heater Installation (Dimensions in millimeters)

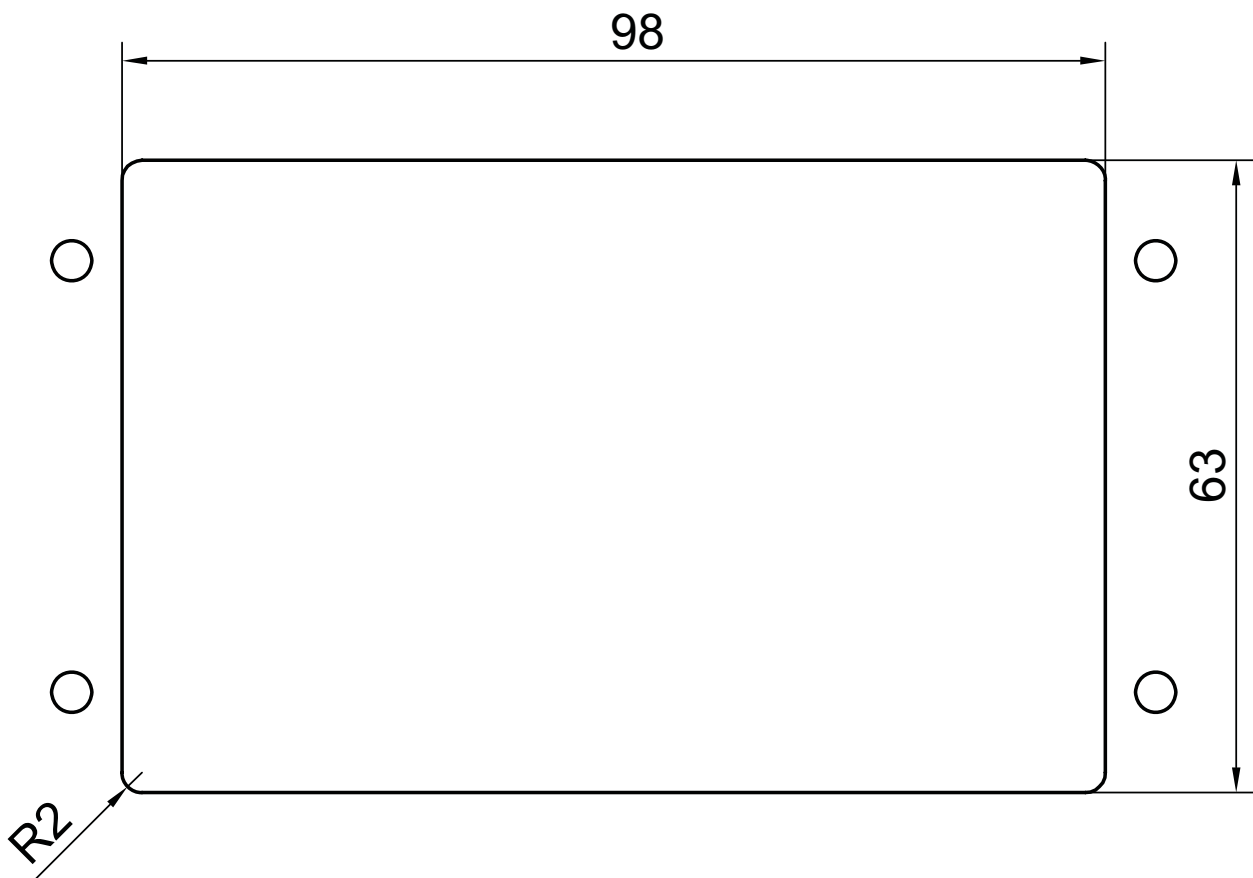
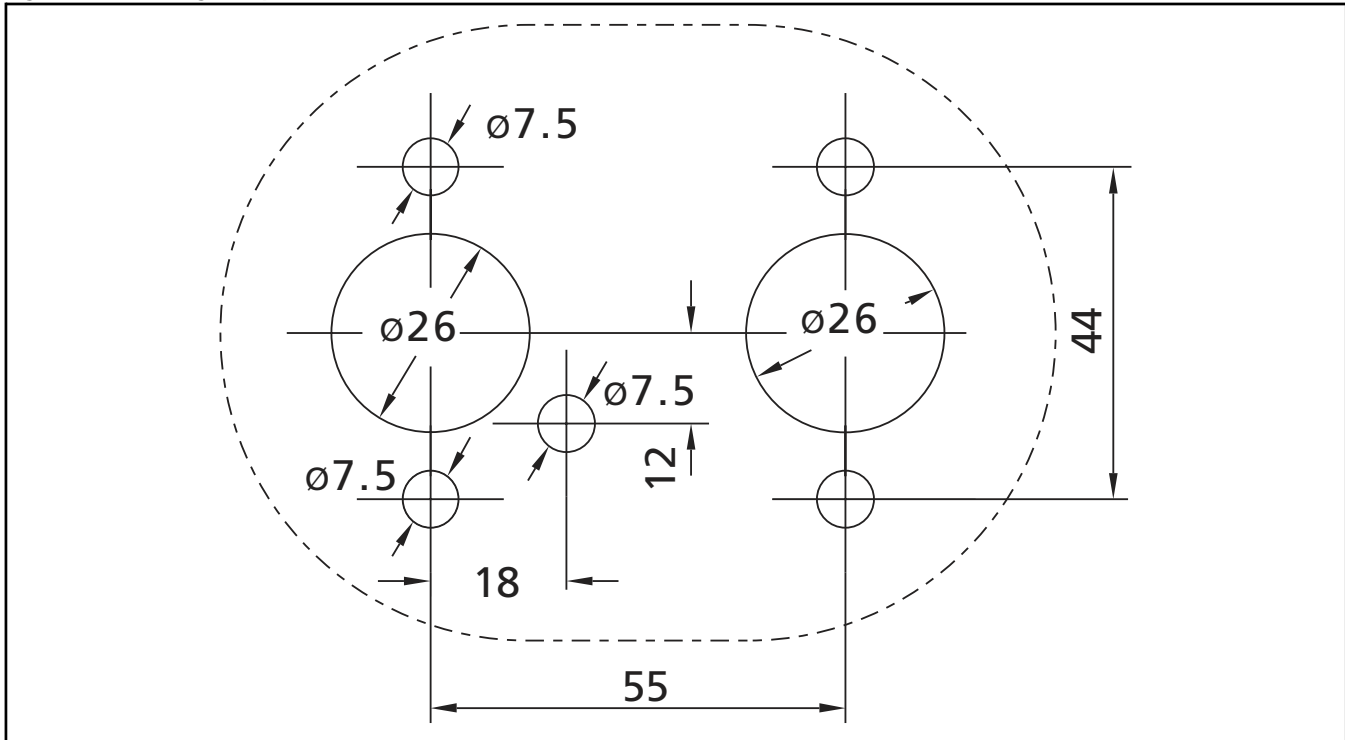

Figure 40. Drilling Template for MC04/05 Control Panel

17. Notes:



Webasto Product N.A., Inc.

15083 North Road
Fenton, MI 48430

Technical Assistance Hotline

USA: (800) 555-4518

Canada: (800) 667-8900

www.webasto.us

www.techwebasto.com